

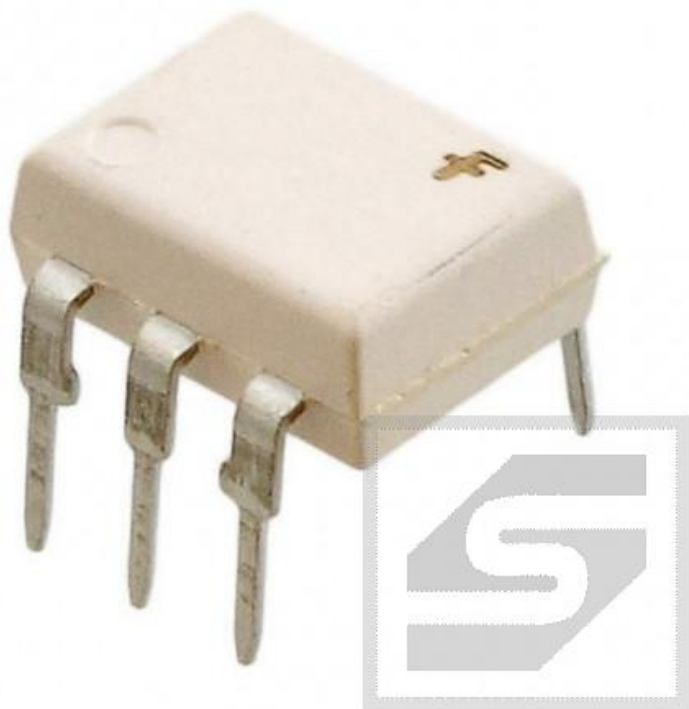

# Optotriak MOC3052 FAIRCHILD DIP6 RoHS



## **Dane techniczne:**

Nazwa: MOC3052

Typ elementu półprzewodnikowego: optotriak

Napięcie izolacji: 5kV

Napięcie wyjściowe: 600V

Rodzaj wyjścia: bez układu przełączania w zerze

Obudowa: DIP6

Napięcie wsteczne maksymalne: 6V

Prąd wyzwiania: 10mA

Montaż: THT

Liczba kanałów: 1



## 6-Pin DIP Random-Phase Optoisolators Triac Drivers (600 Volts Peak)

The MOC3051 Series consists of a GaAs infrared LED optically coupled to a non-Zero-crossing silicon bilateral AC switch (triac). The MOC3051 Series isolates low voltage logic from 115 and 240 Vac lines to provide random phase control of high current triacs or thyristors. The MOC3051 Series features greatly enhanced static dv/dt capability to ensure stable switching performance of inductive loads.

- **To order devices that are tested and marked per VDE 0884 requirements, the suffix "V" must be included at end of part number. VDE 0884 is a test option.**

### Recommended for 115/240 Vac(rms) Applications:

- Solenoid/Valve Controls
- Lamp Ballasts
- Static AC Power Switch
- Interfacing Microprocessors to 115 and 240 Vac Peripherals
- Solid State Relays
- Incandescent Lamp Dimmers
- Temperature Controls
- Motor Controls

### MAXIMUM RATINGS ( $T_A = 25^\circ\text{C}$ unless otherwise noted)

Rating	Symbol	Value	Unit
--------	--------	-------	------

### INFRARED EMITTING DIODE

Reverse Voltage	$V_R$	3	Volts
Forward Current — Continuous	$I_F$	60	mA
Total Power Dissipation @ $T_A = 25^\circ\text{C}$ Negligible Power in Triac Driver Derate above $25^\circ\text{C}$	$P_D$	100 1.33	mW mW/ $^\circ\text{C}$

### OUTPUT DRIVER

Off-State Output Terminal Voltage	$V_{DRM}$	600	Volts
Peak Repetitive Surge Current (PW = 100 $\mu\text{s}$ , 120 pps)	$I_{TSM}$	1	A
Total Power Dissipation @ $T_A = 25^\circ\text{C}$ Derate above $25^\circ\text{C}$	$P_D$	300 4	mW mW/ $^\circ\text{C}$

### TOTAL DEVICE

Isolation Surge Voltage (1) (Peak ac Voltage, 60 Hz, 1 Second Duration)	$V_{ISO}$	7500	Vac(pk)
Total Power Dissipation @ $T_A = 25^\circ\text{C}$ Derate above $25^\circ\text{C}$	$P_D$	330 4.4	mW mW/ $^\circ\text{C}$
Junction Temperature Range	$T_J$	-40 to +100	$^\circ\text{C}$
Ambient Operating Temperature Range	$T_A$	-40 to +85	$^\circ\text{C}$
Storage Temperature Range	$T_{stg}$	-40 to +150	$^\circ\text{C}$
Soldering Temperature (10 s)	$T_L$	260	$^\circ\text{C}$

## MOC3051 MOC3052

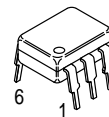

STANDARD THRU HOLE

### COUPLER SCHEMATIC

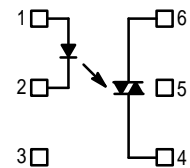

1. ANODE
2. CATHODE
3. NC
4. MAIN TERMINAL
5. SUBSTRATE  
DO NOT CONNECT
6. MAIN TERMINAL

**ELECTRICAL CHARACTERISTICS** ( $T_A = 25^\circ\text{C}$  unless otherwise noted)

Characteristic	Symbol	Min	Typ	Max	Unit
<b>INPUT LED</b>					
Reverse Leakage Current ( $V_R = 3\text{ V}$ )	$I_R$	—	0.05	100	$\mu\text{A}$
Forward Voltage ( $I_F = 10\text{ mA}$ )	$V_F$	—	1.15	1.5	Volts
<b>OUTPUT DETECTOR</b> ( $I_F = 0$ unless otherwise noted)					
Peak Blocking Current, Either Direction (Rated $V_{DRM}$ , Note 1) @ $I_{FT}$ per device	$I_{DRM}$	—	10	100	nA
Peak On-State Voltage, Either Direction ( $I_{TM} = 100\text{ mA Peak}$ )	$V_{TM}$	—	1.7	2.5	Volts
Critical Rate of Rise of Off-State Voltage @ 400 V (Refer to test circuit, Figure 10)	dv/dt static	1000	—	—	$\text{V}/\mu\text{s}$
<b>COUPLED</b>					
LED Trigger Current, Either Direction, Current Required to Latch Output (Main Terminal Voltage = 3 V, Note 2)	$I_{FT}$	—	—	15	mA
		—	—	10	
		—	—	10	
Holding Current, Either Direction	$I_H$	—	280	—	$\mu\text{A}$

1. Test voltage must be applied within dv/dt rating.
2. All devices are guaranteed to trigger at an  $I_F$  value less than or equal to max  $I_{FT}$ . Therefore, recommended operating  $I_F$  lies between max 15 mA for MOC3051, 10 mA for 3052 and absolute max  $I_F$  (60 mA).

**TYPICAL ELECTRICAL CHARACTERISTICS**

$T_A = 25^\circ\text{C}$

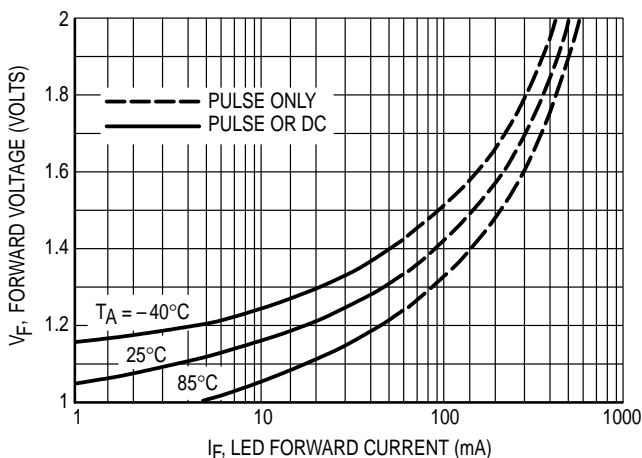

**Figure 1. LED Forward Voltage versus Forward Current**

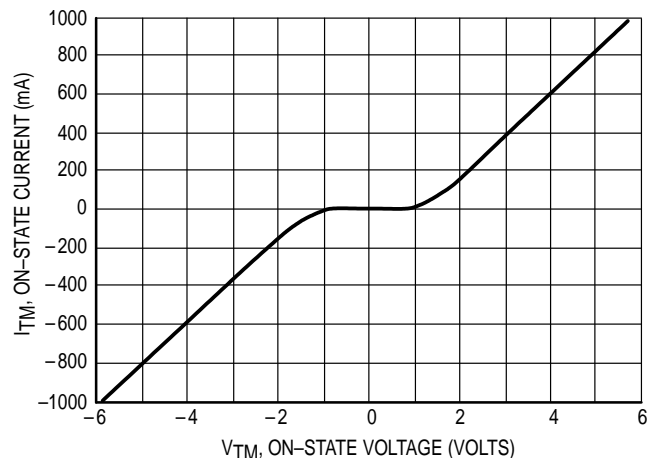

**Figure 2. On-State Characteristics**

**TYPICAL ELECTRICAL CHARACTERISTICS**

$T_A = 25^\circ\text{C}$

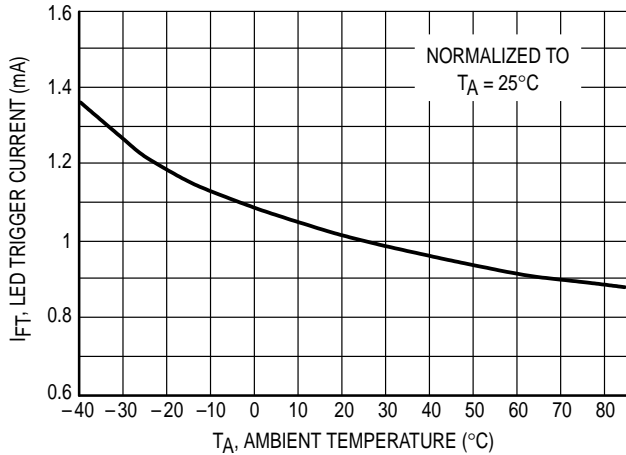

**Figure 3. Trigger Current versus Temperature**

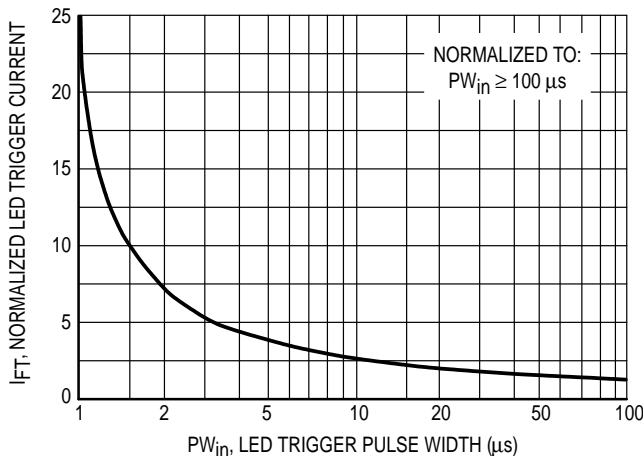

**Figure 4. LED Current Required to Trigger versus LED Pulse Width**

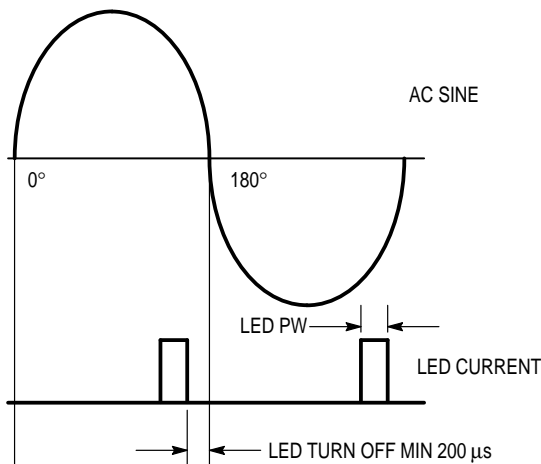

**Figure 5. Minimum Time for LED Turn-Off to Zero Cross of AC Trailing Edge**

**$I_{FT}$  versus Temperature (normalized)**

This graph shows the increase of the trigger current when the device is expected to operate at an ambient temperature below  $25^\circ\text{C}$ . Multiply the normalized  $I_{FT}$  shown on this graph with the data sheet guaranteed  $I_{FT}$ .

Example:

$T_A = -40^\circ\text{C}$ ,  $I_{FT} = 10\text{ mA}$

$I_{FT} @ -40^\circ\text{C} = 10\text{ mA} \times 1.4 = 14\text{ mA}$

**Phase Control Considerations**

**LED Trigger Current versus PW (normalized)**

Random Phase Triac drivers are designed to be phase controllable. They may be triggered at any phase angle within the AC sine wave. Phase control may be accomplished by an AC line zero cross detector and a variable pulse delay generator which is synchronized to the zero cross detector. The same task can be accomplished by a microprocessor which is synchronized to the AC zero crossing. The phase controlled trigger current may be a very short pulse which saves energy delivered to the input LED. LED trigger pulse currents shorter than  $100\ \mu\text{s}$  must have an increased amplitude as shown on Figure 4. This graph shows the dependency of the trigger current  $I_{FT}$  versus the pulse width  $t$  (PW). The reason for the  $I_{FT}$  dependency on the pulse width can be seen on the chart delay  $t(d)$  versus the LED trigger current.

$I_{FT}$  in the graph  $I_{FT}$  versus (PW) is normalized in respect to the minimum specified  $I_{FT}$  for static condition, which is specified in the device characteristic. The normalized  $I_{FT}$  has to be multiplied with the devices guaranteed static trigger current.

Example:

Guaranteed  $I_{FT} = 10\text{ mA}$ , Trigger pulse width  $PW = 3\ \mu\text{s}$

$I_{FT}(\text{pulsed}) = 10\text{ mA} \times 5 = 50\text{ mA}$

**Minimum LED Off Time in Phase Control Applications**

In Phase control applications one intends to be able to control each AC sine half wave from 0 to 180 degrees. Turn on at zero degrees means full power and turn on at 180 degree means zero power. This is not quite possible in reality because triac driver and triac have a fixed turn on time when activated at zero degrees. At a phase control angle close to 180 degrees the driver's turn on pulse at the trailing edge of the AC sine wave must be limited to end  $200\ \mu\text{s}$  before AC zero cross as shown in Figure 5. This assures that the triac driver has time to switch off. Shorter times may cause loss of control at the following half cycle.

**TYPICAL ELECTRICAL CHARACTERISTICS**

$T_A = 25^\circ\text{C}$

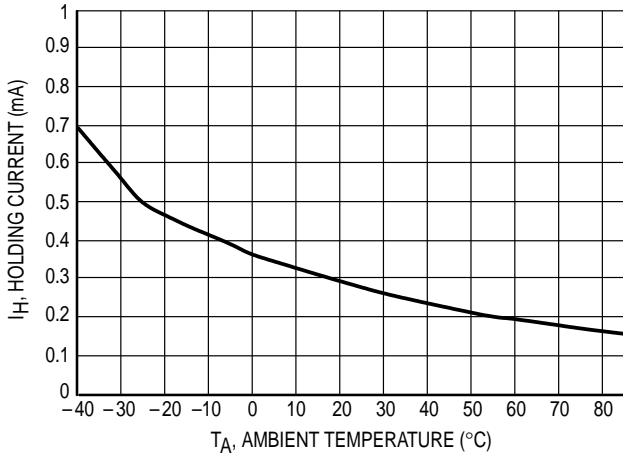

**Figure 6. Holding Current,  $I_H$  versus Temperature**

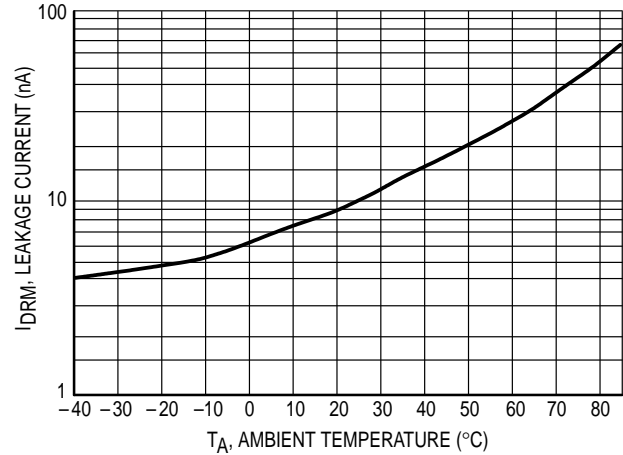

**Figure 7. Leakage Current,  $I_{DRM}$  versus Temperature**

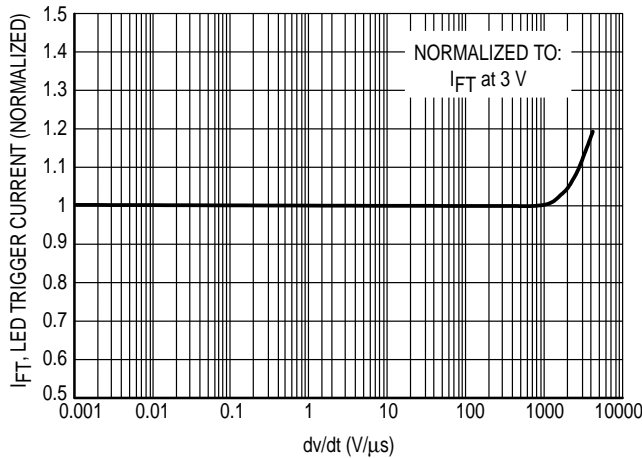

**Figure 8. ED Trigger Current,  $I_{FT}$ , versus  $dv/dt$**

**$I_{FT}$  versus  $dv/dt$**

Triac drivers with good noise immunity ( $dv/dt$  static) have internal noise rejection circuits which prevent false triggering of the device in the event of fast raising line voltage transients. Inductive loads generate a commutating  $dv/dt$  that may activate the triac drivers noise suppression circuits. This prevents the device from turning on at its specified trigger current. It will in this case go into the mode of "half waving" of the load. Half waving of the load may destroy the power triac and the load.

Figure 8 shows the dependency of the triac drivers  $I_{FT}$  versus the reapplied voltage rise with a  $V_p$  of 400 V. This  $dv/dt$  condition simulates a worst case commutating  $dv/dt$  amplitude.

It can be seen that the  $I_{FT}$  does not change until a commutating  $dv/dt$  reaches 1000 V/ $\mu\text{s}$ . Practical loads generate a commutating  $dv/dt$  of less than 50 V/ $\mu\text{s}$ . The data sheet specified  $I_{FT}$  is therefore applicable for all practical inductive loads and load factors.

**TYPICAL ELECTRICAL CHARACTERISTICS**

$T_A = 25^\circ\text{C}$

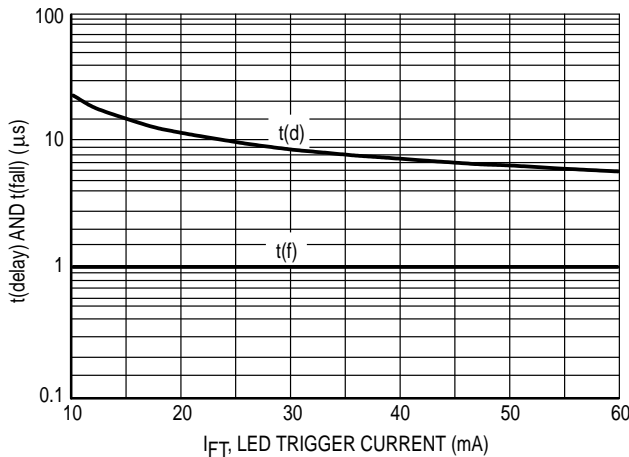

**Figure 9. Delay Time,  $t(d)$ , and Fall Time,  $t(f)$ , versus LED Trigger Current**

**$t(\text{delay}), t(f)$  versus  $I_{FT}$**

The triac driver's turn on switching speed consists of a turn on delay time  $t(d)$  and a fall time  $t(f)$ . Figure 9 shows that the delay time depends on the LED trigger current, while the actual trigger transition time  $t(f)$  stays constant with about one micro second.

The delay time is important in very short pulsed operation because it demands a higher trigger current at very short trigger pulses. This dependency is shown in the graph  $I_{FT}$  versus LED PW.

The turn on transition time  $t(f)$  combined with the power triac's turn on time is important to the power dissipation of this device.

**Switching Time Test Circuit**

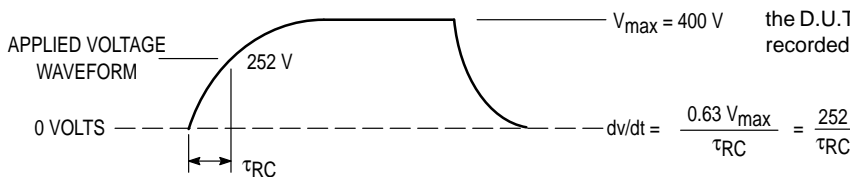
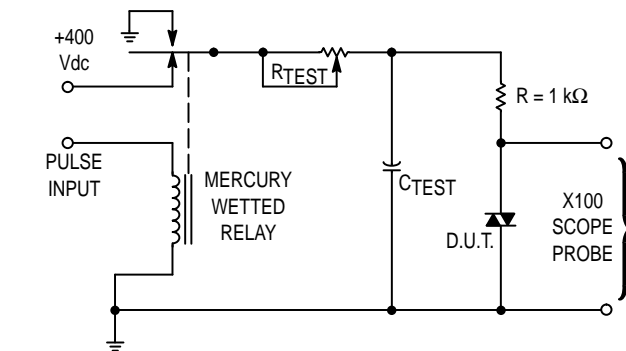
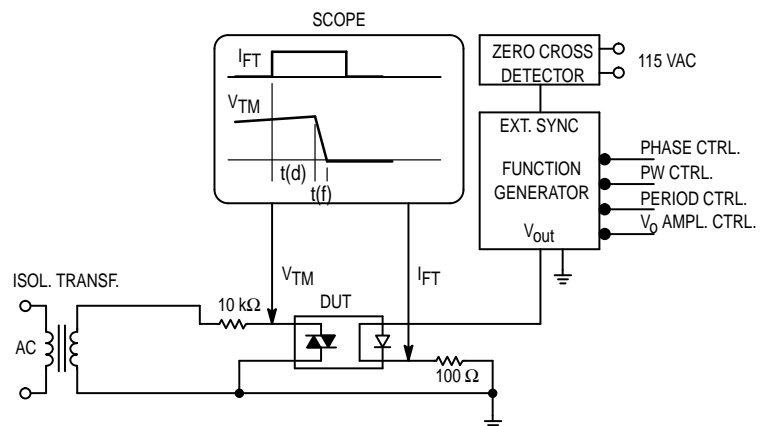

1. The mercury wetted relay provides a high speed repeated pulse to the D.U.T.
2. 100x scope probes are used, to allow high speeds and voltages.
3. The worst-case condition for static  $dv/dt$  is established by triggering the D.U.T. with a normal LED input current, then removing the current. The variable  $R_{TEST}$  allows the  $dv/dt$  to be gradually increased until the D.U.T. continues to trigger in response to the applied voltage pulse, even after the LED current has been removed. The  $dv/dt$  is then decreased until the D.U.T. stops triggering.  $\tau_{RC}$  is measured at this point and recorded.

**Figure 10. Static  $dv/dt$  Test Circuit**

**APPLICATIONS GUIDE**

**Basic Triac Driver Circuit**

The new random phase triac driver family MOC3052 and MOC3051 are very immune to static dv/dt which allows snubberless operations in all applications where external generated noise in the AC line is below its guaranteed dv/dt withstand capability. For these applications a snubber circuit is not necessary when a noise insensitive power triac is used. Figure 11 shows the circuit diagram. The triac driver is directly connected to the triac main terminal 2 and a series Resistor R which limits the current to the triac driver. Current limiting resistor R must have a minimum value which restricts the current into the driver to maximum 1A.

$$R = V_p AC / I_{TM} \text{ max rep.} = V_p AC / 1A$$

The power dissipation of this current limiting resistor and the triac driver is very small because the power triac carries the load current as soon as the current through driver and current limiting resistor reaches the trigger current of the power triac. The switching transition times for the driver is only one micro second and for power triacs typical four micro seconds.

**Triac Driver Circuit for Noisy Environments**

When the transient rate of rise and amplitude are expected to exceed the power triacs and triac drivers maximum ratings a snubber circuit as shown in Figure 12 is recommended. Fast transients are slowed by the R-C snubber and excessive amplitudes are clipped by the Metal Oxide Varistor MOV.

**Triac Driver Circuit for Extremely Noisy Environments,**  
as specified in the noise standards IEEE472 and IEC255-4.

Industrial control applications do specify a maximum transient noise dv/dt and peak voltage which is superimposed onto the AC line voltage. In order to pass this environment noise test a modified snubber network as shown in Figure 13 is recommended.

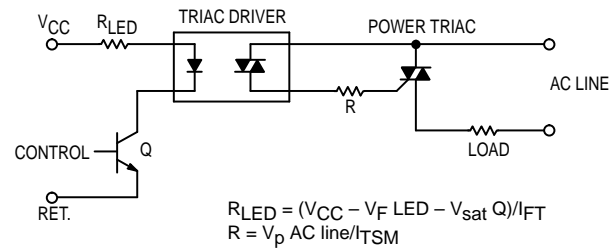

$$R_{LED} = (V_{CC} - V_{F LED} - V_{sat Q}) / I_{FT}$$

$$R = V_p AC \text{ line} / I_{TSM}$$

**Figure 11. Basic Driver Circuit**

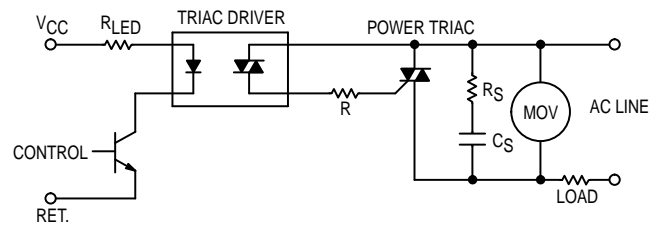

Typical Snubber values  $R_S = 33 \Omega$ ,  $C_S = 0.01 \mu F$   
MOV (Metal Oxide Varistor) protects triac and driver from transient overvoltages  $>V_{DRM \text{ max.}}$

**Figure 12. Triac Driver Circuit for Noisy Environments**

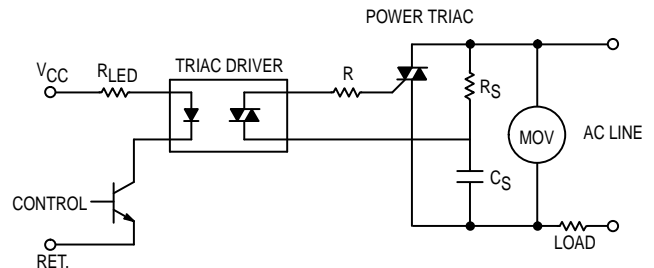

Recommended snubber to pass IEEE472 and IEC255-4 noise tests  
 $R_S = 47 W$ ,  $C_S = 0.01 mF$

**Figure 13. Triac Driver Circuit for Extremely Noisy Environments**

**PACKAGE DIMENSIONS**

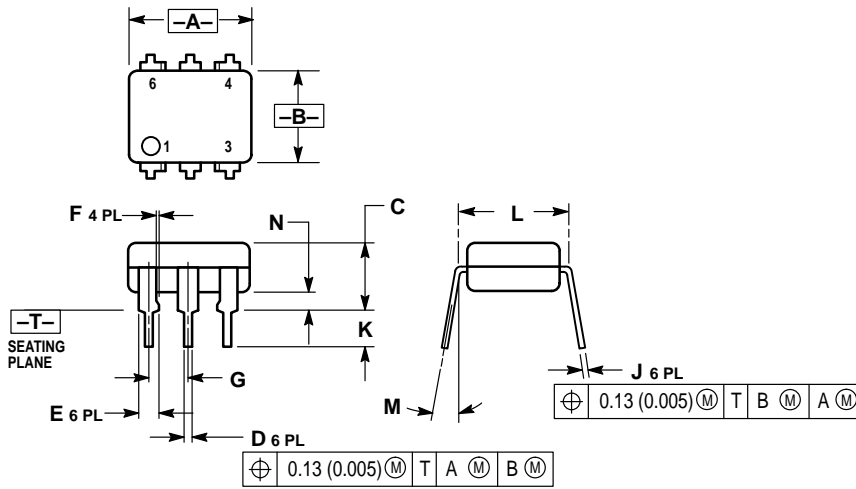

- NOTES:  
1. DIMENSIONING AND TOLERANCING PER ANSI Y14.5M, 1982.  
2. CONTROLLING DIMENSION: INCH.  
3. DIMENSION L TO CENTER OF LEAD WHEN FORMED PARALLEL.

DIM	INCHES		MILLIMETERS	
	MIN	MAX	MIN	MAX
A	0.320	0.350	8.13	8.89
B	0.240	0.260	6.10	6.60
C	0.115	0.200	2.93	5.08
D	0.016	0.020	0.41	0.50
E	0.040	0.070	1.02	1.77
F	0.010	0.014	0.25	0.36
G	0.100	BSC	2.54	BSC
J	0.008	0.012	0.21	0.30
K	0.100	0.150	2.54	3.81
L	0.300	BSC	7.62	BSC
M	0°	15°	0°	15°
N	0.015	0.100	0.38	2.54

- STYLE 6:  
PIN 1. ANODE  
2. CATHODE  
3. NC  
4. MAIN TERMINAL  
5. SUBSTRATE  
6. MAIN TERMINAL

**THRU HOLE**

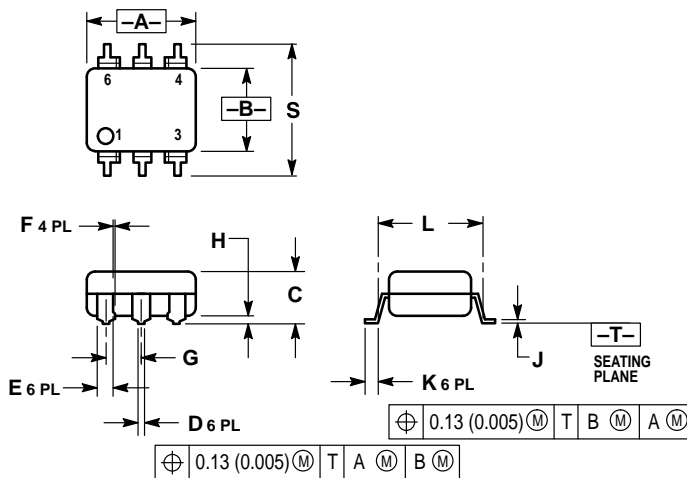

- NOTES:  
1. DIMENSIONING AND TOLERANCING PER ANSI Y14.5M, 1982.  
2. CONTROLLING DIMENSION: INCH.

DIM	INCHES		MILLIMETERS	
	MIN	MAX	MIN	MAX
A	0.320	0.350	8.13	8.89
B	0.240	0.260	6.10	6.60
C	0.115	0.200	2.93	5.08
D	0.016	0.020	0.41	0.50
E	0.040	0.070	1.02	1.77
F	0.010	0.014	0.25	0.36
G	0.100	BSC	2.54	BSC
H	0.020	0.025	0.51	0.63
J	0.008	0.012	0.20	0.30
K	0.006	0.035	0.16	0.88
L	0.320	BSC	8.13	BSC
S	0.332	0.390	8.43	9.90

**SURFACE MOUNT**



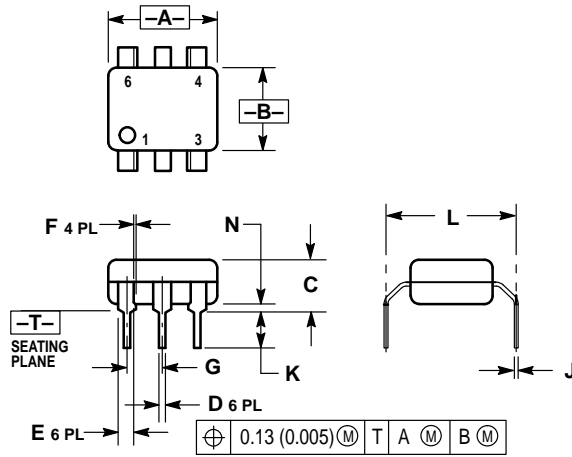

- NOTES:
1. DIMENSIONING AND TOLERANCING PER ANSI Y14.5M, 1982.
  2. CONTROLLING DIMENSION: INCH.
  3. DIMENSION L TO CENTER OF LEAD WHEN FORMED PARALLEL.

DIM	INCHES		MILLIMETERS	
	MIN	MAX	MIN	MAX
A	0.320	0.350	8.13	8.89
B	0.240	0.260	6.10	6.60
C	0.115	0.200	2.93	5.08
D	0.016	0.020	0.41	0.50
E	0.040	0.070	1.02	1.77
F	0.010	0.014	0.25	0.36
G	0.100 BSC		2.54 BSC	
J	0.008	0.012	0.21	0.30
K	0.100	0.150	2.54	3.81
L	0.400	0.425	10.16	10.80
N	0.015	0.040	0.38	1.02

**0.4" LEAD SPACING**

#### **DISCLAIMER**

FAIRCHILD SEMICONDUCTOR RESERVES THE RIGHT TO MAKE CHANGES WITHOUT FURTHER NOTICE TO ANY PRODUCTS HEREIN TO IMPROVE RELIABILITY, FUNCTION OR DESIGN. FAIRCHILD DOES NOT ASSUME ANY LIABILITY ARISING OUT OF THE APPLICATION OR USE OF ANY PRODUCT OR CIRCUIT DESCRIBED HEREIN; NEITHER DOES IT CONVEY ANY LICENSE UNDER ITS PATENT RIGHTS, NOR THE RIGHTS OF OTHERS.

#### **LIFE SUPPORT POLICY**

FAIRCHILD'S PRODUCTS ARE NOT AUTHORIZED FOR USE AS CRITICAL COMPONENTS IN LIFE SUPPORT DEVICES OR SYSTEMS WITHOUT THE EXPRESS WRITTEN APPROVAL OF THE PRESIDENT OF FAIRCHILD SEMICONDUCTOR CORPORATION. As used herein:

1. Life support devices or systems are devices or systems which, (a) are intended for surgical implant into the body, or (b) support or sustain life, and (c) whose failure to perform when properly used in accordance with instructions for use provided in the labeling, can be reasonably expected to result in a significant injury of the user.
2. A critical component in any component of a life support device or system whose failure to perform can be reasonably expected to cause the failure of the life support device or system, or to affect its safety or effectiveness.

This datasheet has been download from:

[www.datasheetcatalog.com](http://www.datasheetcatalog.com)

Datasheets for electronics components.