



# Dioda D66-200-10-NO-1BH(200A/1000V) z płaską podstawą



## Dane techniczne:

Nazwa: D66-200-10-NO-1BH

Typ diody: prostownicza

Napięcie: 1000V

Prąd: 200A

Charakterystyka: z płaską podstawą

Katoda

Producent: LAMINA

Diodes type D66 are of modern design with internal spring loaded contacts and pressure welded glass-to-metal seal. Designed for use in power electronic circuits and equipment under normal operating conditions.

### KEY PARAMETERS

$U_{RRM}$	up to 1600 V
$I_{F(AV)}$	200 A
$I_{FSM}$	5000 A

### FEATURES

- all diffused design
- high current capabilities
- high surge current capabilities
- high rates voltages
- low thermal impedance
- tested according to IEC standards
- compact size and small weight

### APPLICATION

- High Voltage Power Supplies
- Motor Control
- Battery Chargers
- Free Wheeling Diode
- Resistance Welding

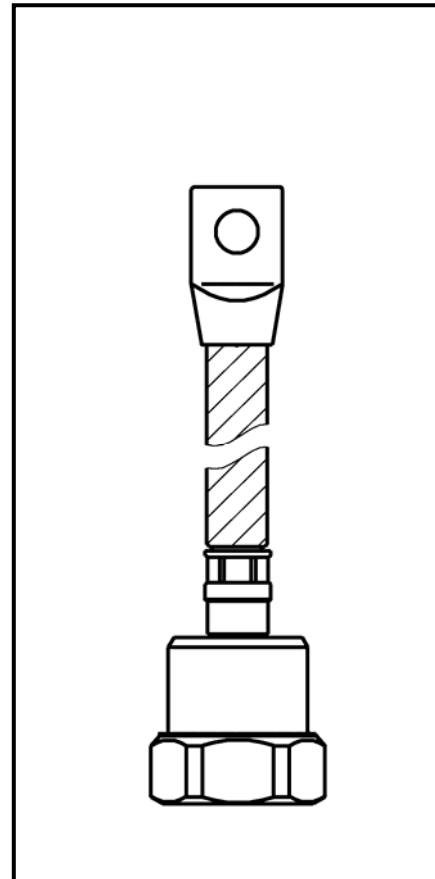

See package details for further information

Designed for use in high power industrial and commercial power electronic circuits and equipment where high currents are encountered and high reliability is essential.

# D66-200

## Diode

**LAMINA S.I.**

KKD66200, October 2006 version

### ORDERING INFORMATION

When ordering please refer to device code builder presented below.  
Please use the complete part number when ordering, quote or in any future correspondence relating to your order.

**D66-200-□□-□0**

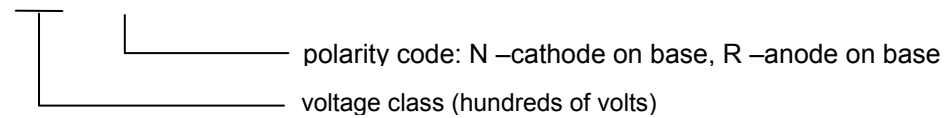

### ELECTRICAL PARAMETERS

#### Voltage ratings

Voltage class	$U_{RRM}$	$U_{RSM}$	$I_{RRM}$
	V	V	mA
04	400	500	50
06	600	700	
08	800	900	
10	1000	1100	
12	1200	1300	
14	1400	1500	
16	1600	1700	

LAMINA Semiconductors International Ltd.  
Puławska 34  
PL-05-500 Piaseczno  
POLAND

Tel.: +48-22-7570745  
Fax.: +48-22-7572734  
e-mail: office@laminasi.com.pl  
www.laminasi.com.pl

# D66-200

## Diode

**LAMINA S.I.**

KKD66200, October 2006 version

### Electrical properties

Parameter	Unit	Test conditions	Value
Average forward current @ case temperature	$I_{F(AV)}$	A	200
	$T_c$	°C	$U_{RRM} \leq 1200V$ 145 $U_{RRM} > 1200V$ 130
RMS forward current	$I_{F(RMS)}$	A	315
Surge current	$I_{FSM}$	A	$T_j = T_{jmax}$ , $U_R = 0,8U_{RRM}$ , $t_p = 10ms$
$I^2t$ – value	$I^2t$	kA <sup>2</sup> s	125
Forward voltage drop max.	$U_{FM}$	V	$T_j = 25^\circ C$ , $I_{FM} = 800A$
Threshold voltage	$U_{F(T0)}$	V	0,72
Slope resistance	$r_F$	mΩ	1,85

### Thermal properties

Parameter	Unit	Test conditions	Value
Thermal resistance, junction to case	$R_{thJC}$	°C/W	DC 0,12
Thermal resistance, case to heatsink	$R_{thCS}$	°C/W	0,10
Operating junction temperature	$T_{jmin} \dots T_{jmax}$	°C	$U_{RRM} \leq 1200V$ -40...+190 $U_{RRM} > 1200V$ -40...+175
Storage temperature	$T_{stg}$	°C	-40...+190

### Mechanical properties

Parameter	Unit	Value
Mounting force	F	kN 3,5
Weight	m	g 200

LAMINA Semiconductors International Ltd.  
Puławska 34  
PL-05-500 Piaseczno  
POLAND

Tel.: +48-22-7570745  
Fax.: +48-22-7572734  
e-mail: office@laminasi.com.pl  
www.laminasi.com.pl

# D66-200

## Diode

**LAMINA S.I.**

KKD66200, October 2006 version

### Package details

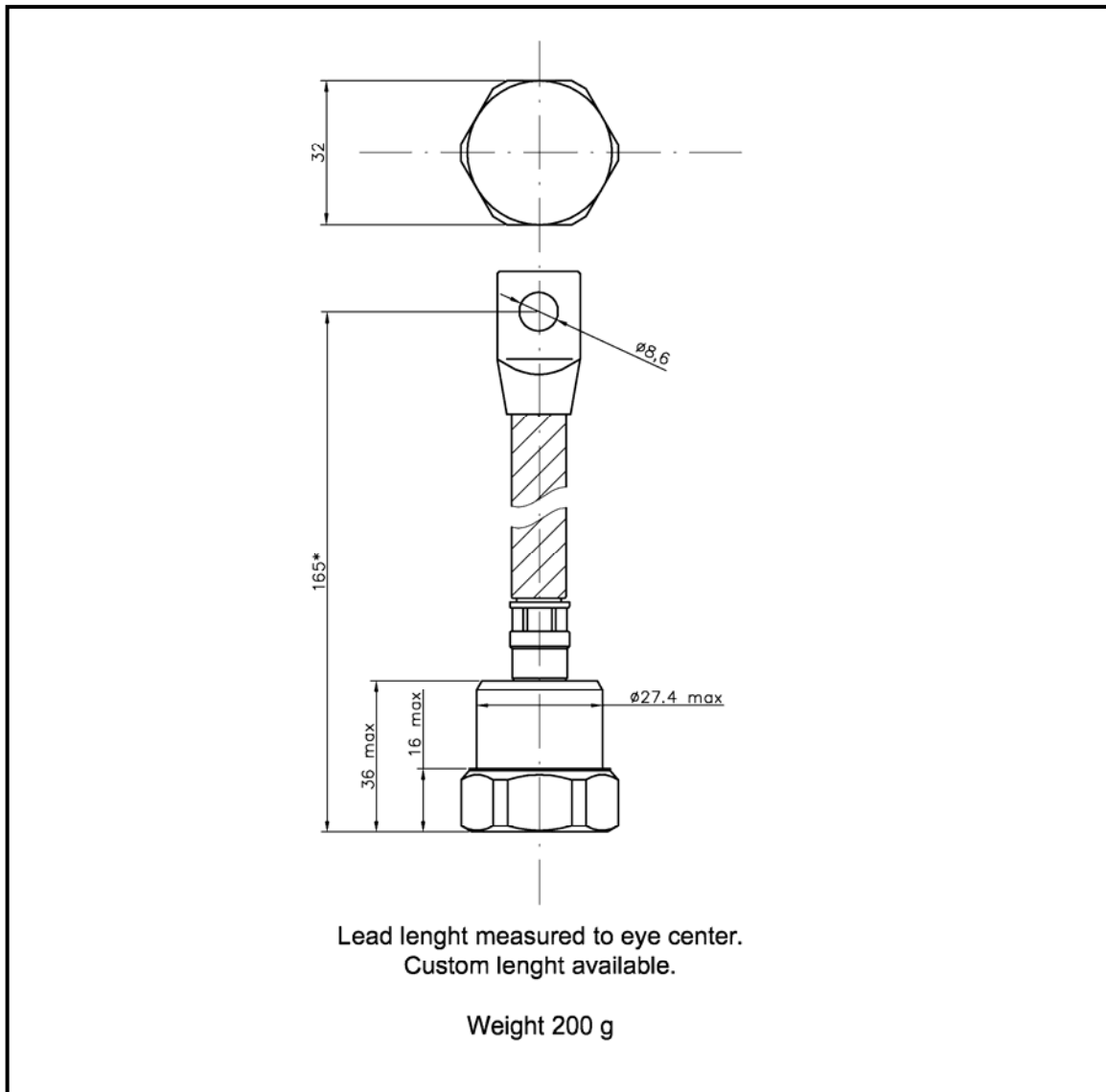

For further package information, please contact Sales & Marketing Department. All dimensions in mm, unless stated otherwise.  
Do not scale.

**LAMINA Semiconductors International Ltd.**  
Puławska 34  
PL-05-500 Piaseczno  
POLAND

Tel.: +48-22-7570745  
Fax.: +48-22-7572734  
e-mail: office@laminasi.com.pl  
www.laminasi.com.pl

# D66-200

## Diode

**LAMINA S.I.**

KKD66200, October 2006 version

### CHARACTERISTICS

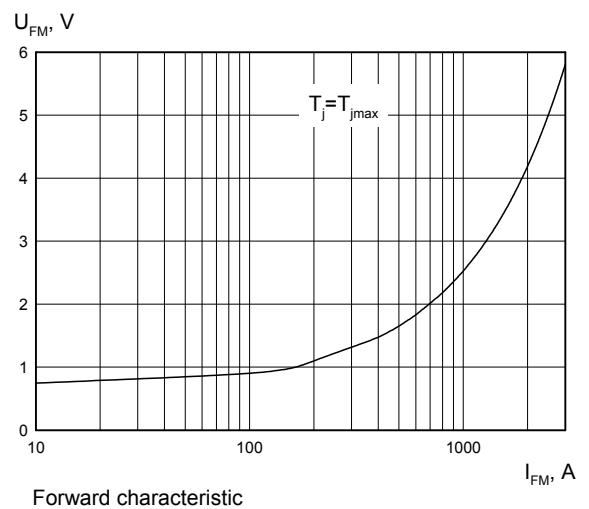
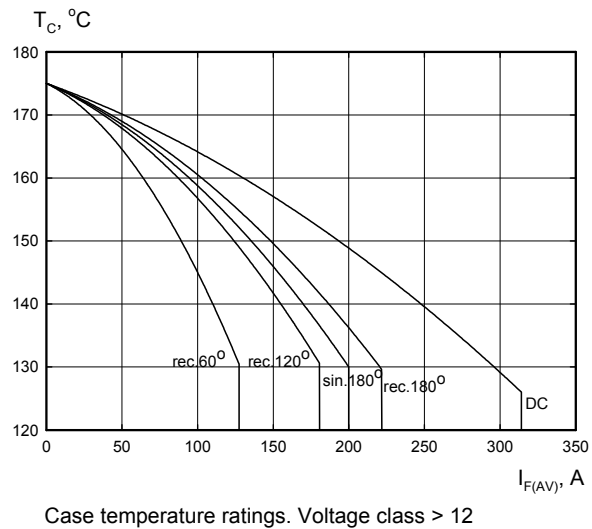
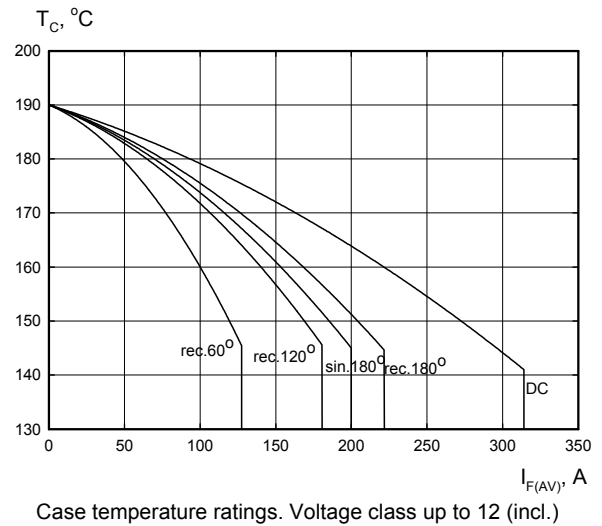
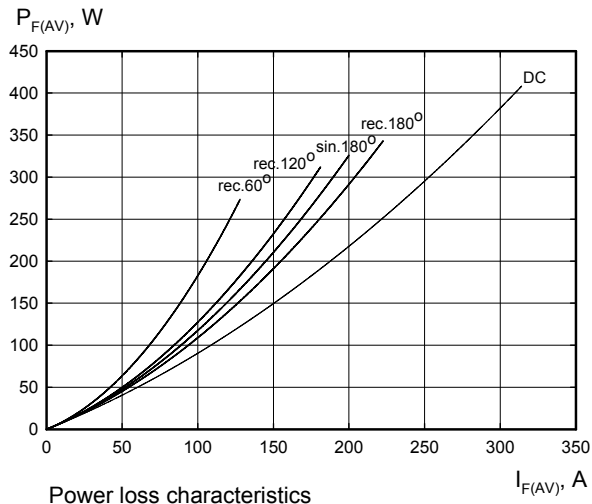

LAMINA Semiconductors International Ltd.  
 Puławska 34  
 PL-05-500 Piaseczno  
 POLAND

Tel.: +48-22-7570745  
 Fax.: +48-22-7572734  
 e-mail: office@laminasi.com.pl  
 www.laminasi.com.pl

# D66-200

## Diode

**LAMINA S.I.**

KKD66200, October 2006 version

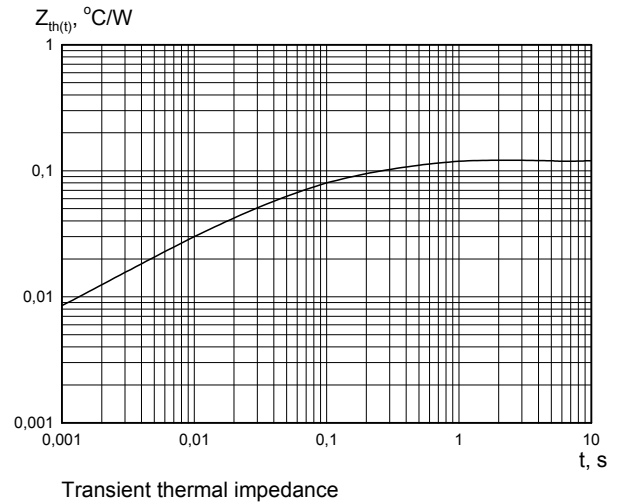
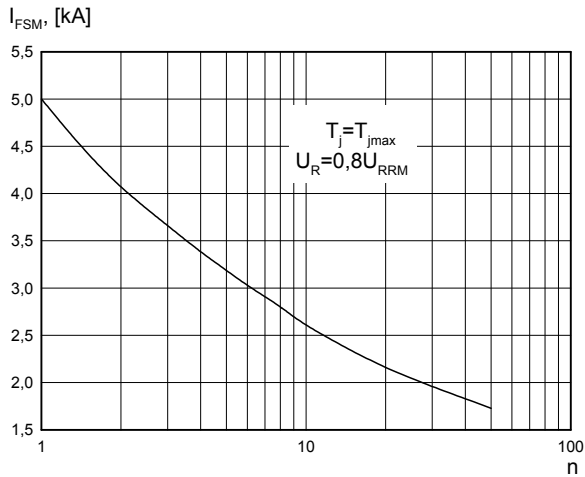

## HEATSINKS

LAMINA S.I. has its own proprietary range of extruded aluminium heatsinks designed to optimise the performance of our semiconductors with natural and forced air flow.

## POWER ASSEMBLY CAPABILITY

LAMINA S.I. provides a support for those customers requiring more than a basic semiconductor and offers precisely assembled Power Blocks according to factory or customer standards.

LAMINA Semiconductors International Ltd.  
Puławska 34  
PL-05-500 Piaseczno  
POLAND

Tel.: +48-22-7570745  
Fax.: +48-22-7572734  
e-mail: office@laminasi.com.pl  
www.laminasi.com.pl