



# STP40N20 STB40N20 - STW40N20

N-CHANNEL 200V - 0.038Ω - 40A TO-220/TO-247/D<sup>2</sup>PAK  
LOW GATE CHARGE STripFET™ MOSFET

**Table 1: General Features**

TYPE	V <sub>DSS</sub>	R <sub>DS(on)</sub>	I <sub>D</sub>	P <sub>w</sub>
STP40N20	200 V	< 0.045 Ω	40 A	160 W
STW40N20	200 V	< 0.045 Ω	40 A	160 W
STB40N20	200 V	< 0.045 Ω	40 A	160 W

- TYPICAL R<sub>DS(on)</sub> = 0.038 Ω
- GATE CHARGE MINIMIZED
- VERY LOW INTRINSIC CAPACITANCES
- VERY GOOD MANUFACTURING REPEATABILITY
- EXCELLENT FIGURE OF MERIT (R<sub>DS</sub>\*Q<sub>g</sub>)
- 100% AVALANCHE TESTED

**DESCRIPTION**

This MOSFET series realized with STMicroelectronics unique STripFET process has specifically been designed to minimize input capacitance and gate charge. It is therefore suitable as primary switch in advanced high-efficiency isolated DC-DC converters.

**APPLICATIONS**

- HIGH CURRENT, HIGH SPEED SWITCHING
- UPS

**Figure 1: Package**

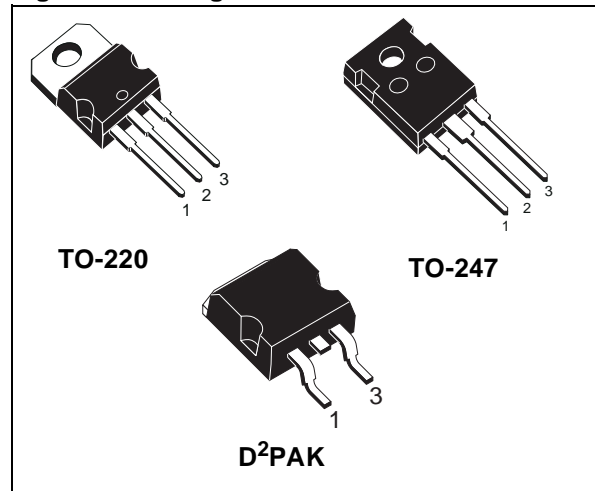

**Figure 2: Internal Schematic Diagram**

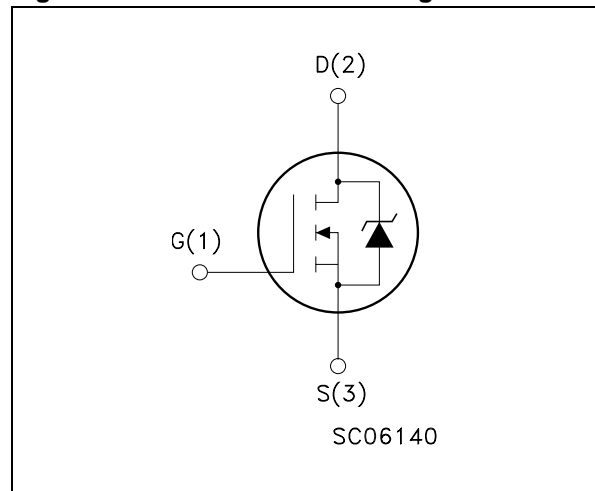

**Table 2: Order Codes**

SALES TYPE	MARKING	PACKAGE	PACKAGING
STP40N20	P40N20	TO-220	TUBE
STW40N20	W40N20	TO-247	TUBE
STB40N20	B40N20	D <sup>2</sup> PAK	TAPE & REEL

## STB40N20 - STP40N20 - STW40N20

**Table 3: Absolute Maximum ratings**

Symbol	Parameter	Value	Unit
$V_{DS}$	Drain-source Voltage ( $V_{GS} = 0$ )	200	V
$V_{DGR}$	Drain-gate Voltage ( $R_{GS} = 20 \text{ k}\Omega$ )	200	V
$V_{GS}$	Gate- source Voltage	$\pm 20$	V
$I_D$	Drain Current (continuous) at $T_C = 25^\circ\text{C}$	40	A
$I_D$	Drain Current (continuous) at $T_C = 100^\circ\text{C}$	25	A
$I_{DM}(\bullet)$	Drain Current (pulsed)	160	A
$P_{TOT}$	Total Dissipation at $T_C = 25^\circ\text{C}$	160	W
	Derating Factor	1.28	W/ $^\circ\text{C}$
dv/dt (1)	Peak Diode Recovery voltage slope	12	V/ns
$T_j$ $T_{stg}$	Operating Junction Temperature Storage Temperature	-55 to 150	$^\circ\text{C}$

( $\bullet$ ) Pulse width limited by safe operating area

(1)  $I_{SD} \leq 40\text{A}$ ,  $di/dt \leq 200 \text{ A}/\mu\text{s}$ ,  $V_{DD} \leq V_{(BR)DSS}$ ,  $T_j \leq T_{JMAX}$ .

**Table 4: Thermal Data**

		TO-220/	TO-247	
Rthj-case	Thermal Resistance Junction-case Max	0.78		$^\circ\text{C}/\text{W}$
Rthj-amb	Thermal Resistance Junction-ambient Max	62.5	50	$^\circ\text{C}/\text{W}$
$T_l$	Maximum Lead Temperature For Soldering Purpose	300		$^\circ\text{C}$

**Table 5: Avalanche Characteristics**

Symbol	Parameter	Max Value	Unit
$I_{AR}$	Avalanche Current, Repetitive or Not-Repetitive (pulse width limited by $T_j$ max)	40	A
$E_{AS}$	Single Pulse Avalanche Energy (starting $T_j = 25^\circ\text{C}$ , $I_D = I_{AR}$ , $V_{DD} = 50 \text{ V}$ )	230	mJ

**ELECTRICAL CHARACTERISTICS** ( $T_{CASE} = 25^{\circ}C$  UNLESS OTHERWISE SPECIFIED)

**Table 6: On/Off**

Symbol	Parameter	Test Conditions	Min.	Typ.	Max.	Unit
$V_{(BR)DSS}$	Drain-source Breakdown Voltage	$I_D = 1mA, V_{GS} = 0$	200			V
$I_{DSS}$	Zero Gate Voltage Drain Current ( $V_{GS} = 0$ )	$V_{DS} = \text{Max Rating}$ $V_{DS} = \text{Max Rating}, T_C = 125^{\circ}C$			1 10	$\mu A$ $\mu A$
$I_{GSS}$	Gate-body Leakage Current ( $V_{DS} = 0$ )	$V_{GS} = \pm 20V$			$\pm 100$	nA
$V_{GS(th)}$	Gate Threshold Voltage	$V_{DS} = V_{GS}, I_D = 250 \mu A$	2	3	4	V
$R_{DS(on)}$	Static Drain-source On Resistance	$V_{GS} = 10V, I_D = 20 A$		0.038	0.045	$\Omega$

**Table 7: Dynamic**

Symbol	Parameter	Test Conditions	Min.	Typ.	Max.	Unit
$g_{fs} (1)$	Forward Transconductance	$V_{DS} = 15 V, I_D = 20 A$		30		S
$C_{iss}$ $C_{oss}$ $C_{rss}$	Input Capacitance Output Capacitance Reverse Transfer Capacitance	$V_{DS} = 25V, f = 1 \text{ MHz}, V_{GS} = 0$		2500 510 78		pF pF pF
$t_{d(on)}$ $t_r$ $t_{d(off)}$ $t_f$	Turn-on Delay Time Rise Time Turn-off Delay Time Fall Time	$V_{DD} = 100 V, I_D = 20 A,$ $R_G = 4.7 \Omega, V_{GS} = 10 V$ (Resistive Load see, Figure 17)		20 44 74 22		ns ns ns ns
$Q_g$ $Q_{gs}$ $Q_{gd}$	Total Gate Charge Gate-Source Charge Gate-Drain Charge	$V_{DD} = 160V, I_D = 40 A,$ $V_{GS} = 10V$		75 13.2 35.5		nC nC nC

**Table 8: Source Drain Diode**

Symbol	Parameter	Test Conditions	Min.	Typ.	Max.	Unit
$I_{SD}$ $I_{SDM} (2)$	Source-drain Current Source-drain Current (pulsed)				40 160	A A
$V_{SD} (1)$	Forward On Voltage	$I_{SD} = 20 A, V_{GS} = 0$			1.5	V
$t_{rr}$ $Q_{rr}$ $I_{RRM}$	Reverse Recovery Time Reverse Recovery Charge Reverse Recovery Current	$I_{SD} = 20 A, di/dt = 100A/\mu s$ $V_{DD} = 100V, T_j = 25^{\circ}C$ (see test circuit, Figure 18)		192 922 9.6		ns nC A
$t_{rr}$ $Q_{rr}$ $I_{RRM}$	Reverse Recovery Time Reverse Recovery Charge Reverse Recovery Current	$I_{SD} = 20 A, di/dt = 100A/\mu s$ $V_{DD} = 100V, T_j = 150^{\circ}C$ (see test circuit, Figure 18)		242 1440 11.9		ns nC A

(1) Pulsed: Pulse duration = 300  $\mu s$ , duty cycle 1.5 %.

(2) Pulse width limited by safe operating area.

Figure 3: Safe Operating Area For TO-220/D<sup>2</sup>PAK

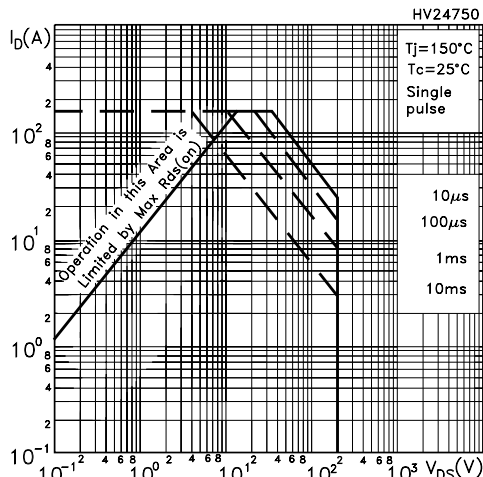

Figure 4: Safe Operating Area For TO-247

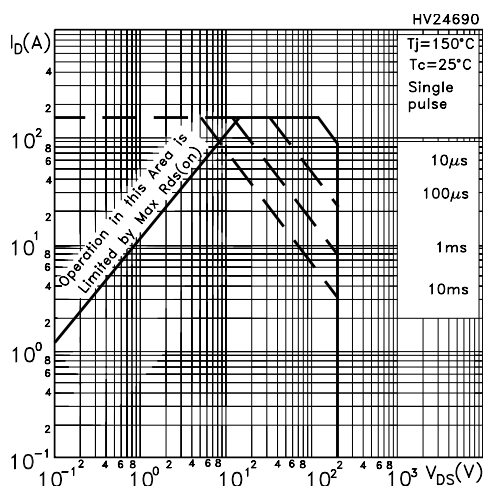

Figure 5: Output Characteristics

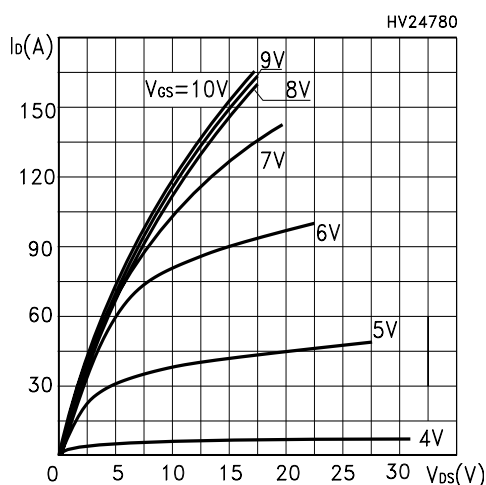

Figure 6: Thermal Impedance For TO-220/D<sup>2</sup>PAK

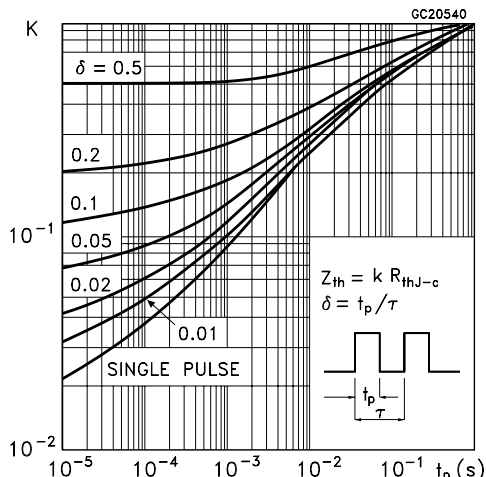

Figure 7: Thermal Impedance For TO-247

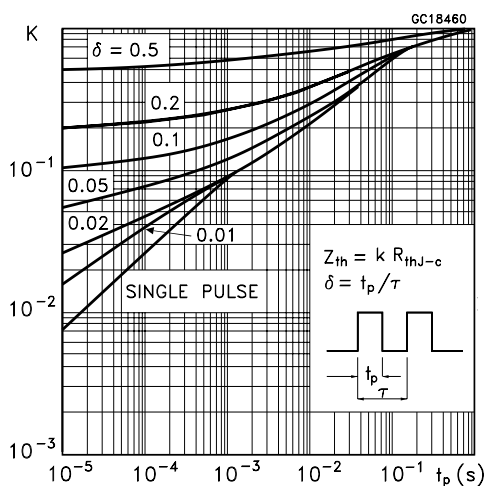

Figure 8: Transfer Characteristics

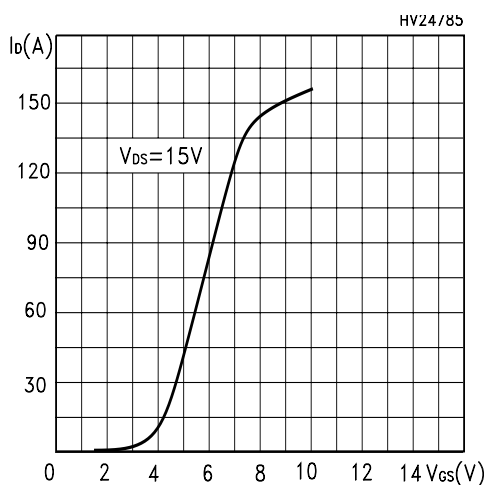

Figure 9: Transconductance

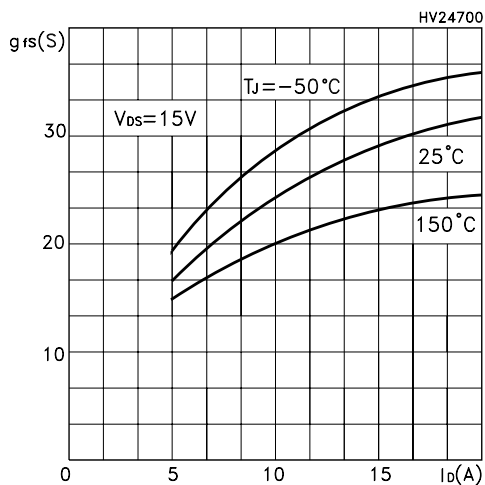

Figure 10: Gate Charge vs Gate-source Voltage

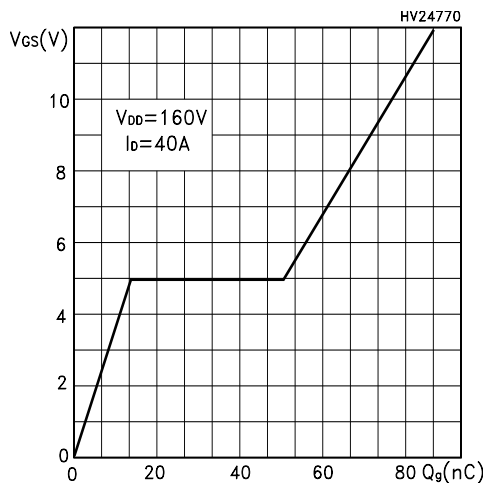

Figure 11: Normalized Gate Threshold Voltage vs Temperature

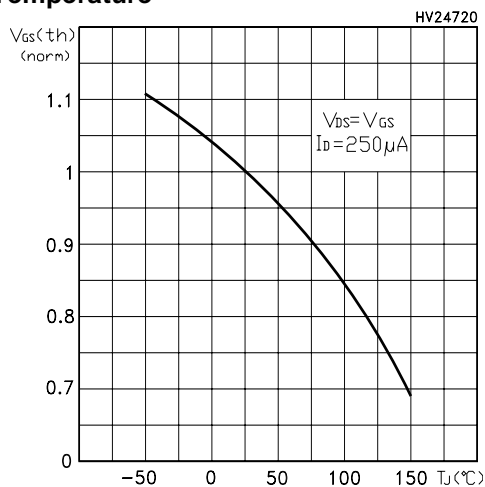

Figure 12: Static Drain-source On Resistance

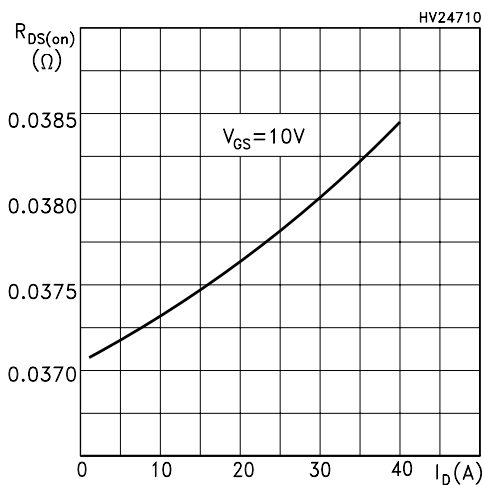

Figure 13: Capacitance Variations

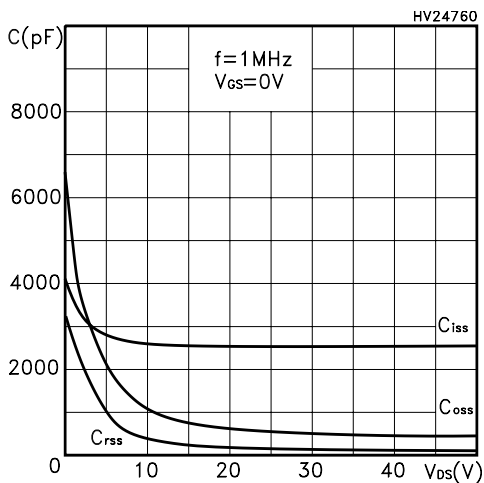

Figure 14: Normalized On Resistance vs Temperature

Figure 15: Source-Drain Forward Characteristics

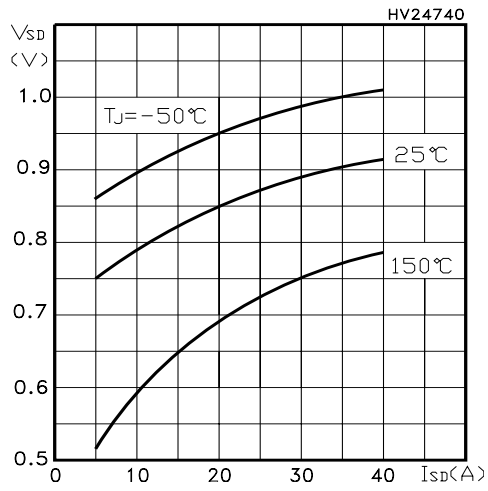

Figure 16: Unclamped Inductive Load Test Circuit

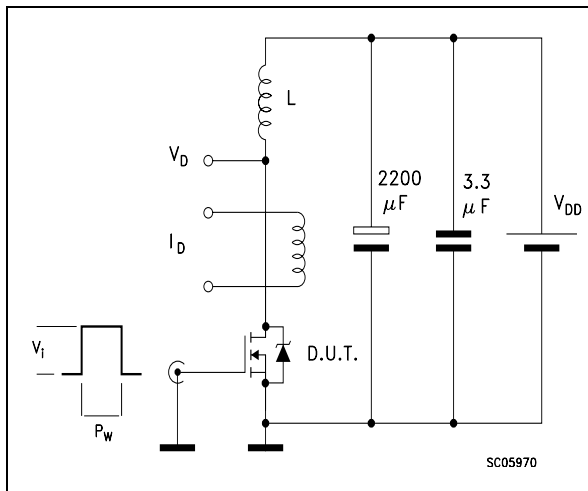

Figure 17: Switching Times Test Circuit For Resistive Load

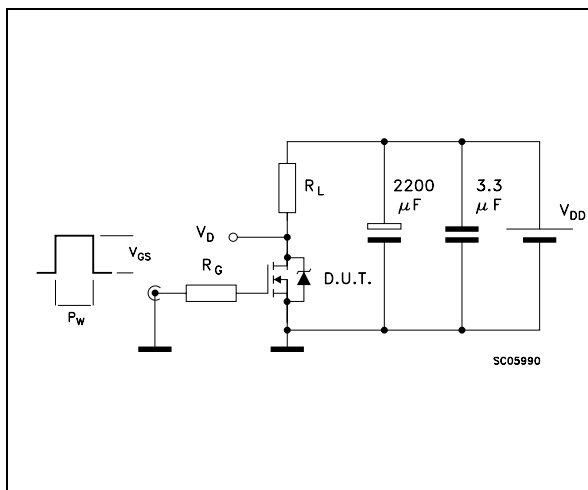

Figure 18: Test Circuit For Inductive Load Switching and Diode Recovery Times

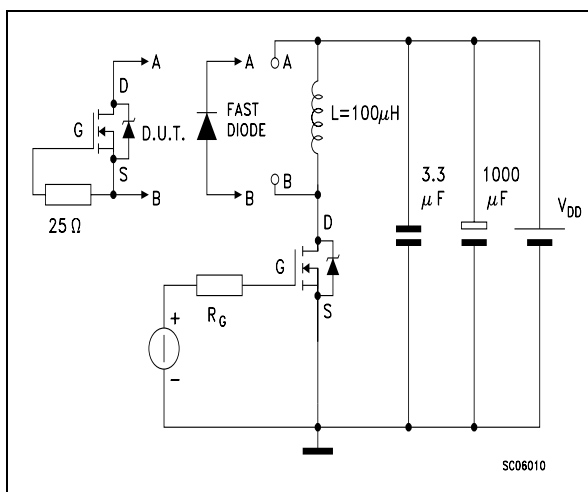

Figure 19: Unclamped Inductive Waform

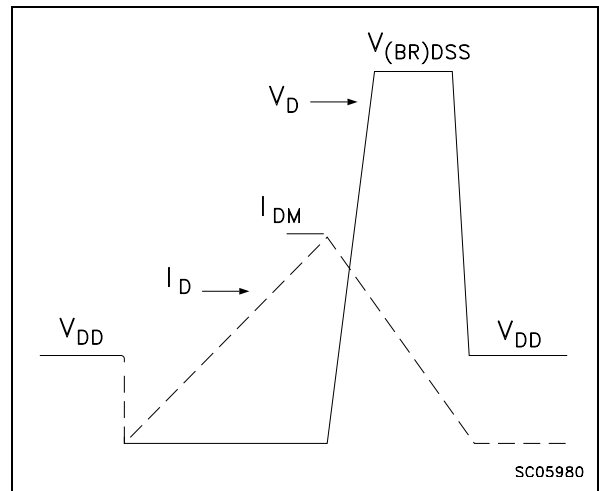
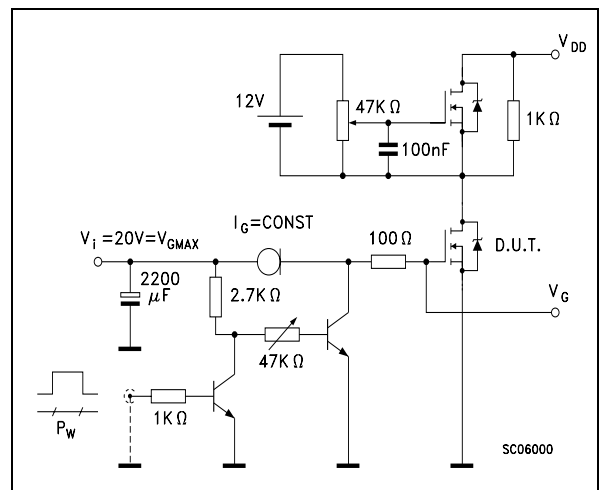
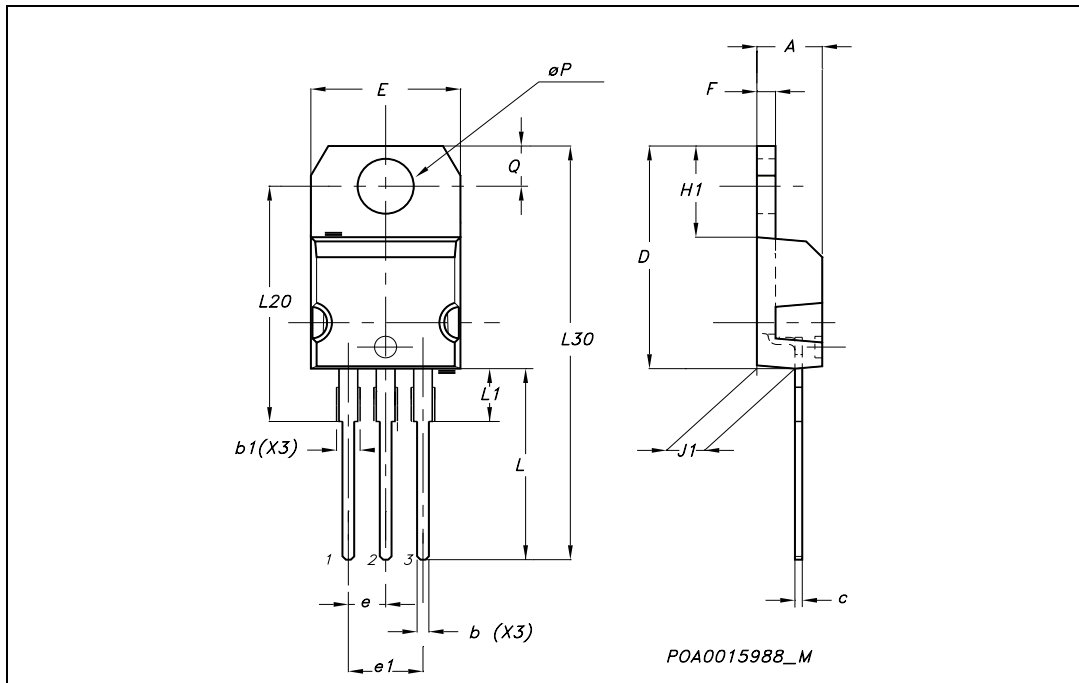

Figure 20: Gate Charge Test Circuit



**TO-220 MECHANICAL DATA**

DIM.	mm.			inch		
	MIN.	TYP.	MAX.	MIN.	TYP.	MAX.
A	4.40		4.60	0.173		0.181
b	0.61		0.88	0.024		0.034
b1	1.15		1.70	0.045		0.066
c	0.49		0.70	0.019		0.027
D	15.25		15.75	0.60		0.620
E	10		10.40	0.393		0.409
e	2.40		2.70	0.094		0.106
e1	4.95		5.15	0.194		0.202
F	1.23		1.32	0.048		0.052
H1	6.20		6.60	0.244		0.256
J1	2.40		2.72	0.094		0.107
L	13		14	0.511		0.551
L1	3.50		3.93	0.137		0.154
L20		16.40			0.645	
L30		28.90			1.137	
øP	3.75		3.85	0.147		0.151
Q	2.65		2.95	0.104		0.116





TO-247 MECHANICAL DATA

DIM.	mm.			inch		
	MIN.	TYP	MAX.	MIN.	TYP.	MAX.
A	4.85		5.15	0.19		0.20
A1	2.20		2.60	0.086		0.102
b	1.0		1.40	0.039		0.055
b1	2.0		2.40	0.079		0.094
b2	3.0		3.40	0.118		0.134
c	0.40		0.80	0.015		0.03
D	19.85		20.15	0.781		0.793
E	15.45		15.75	0.608		0.620
e		5.45			0.214	
L	14.20		14.80	0.560		0.582
L1	3.70		4.30	0.14		0.17
L2		18.50			0.728	
øP	3.55		3.65	0.140		0.143
øR	4.50		5.50	0.177		0.216
S		5.50			0.216	

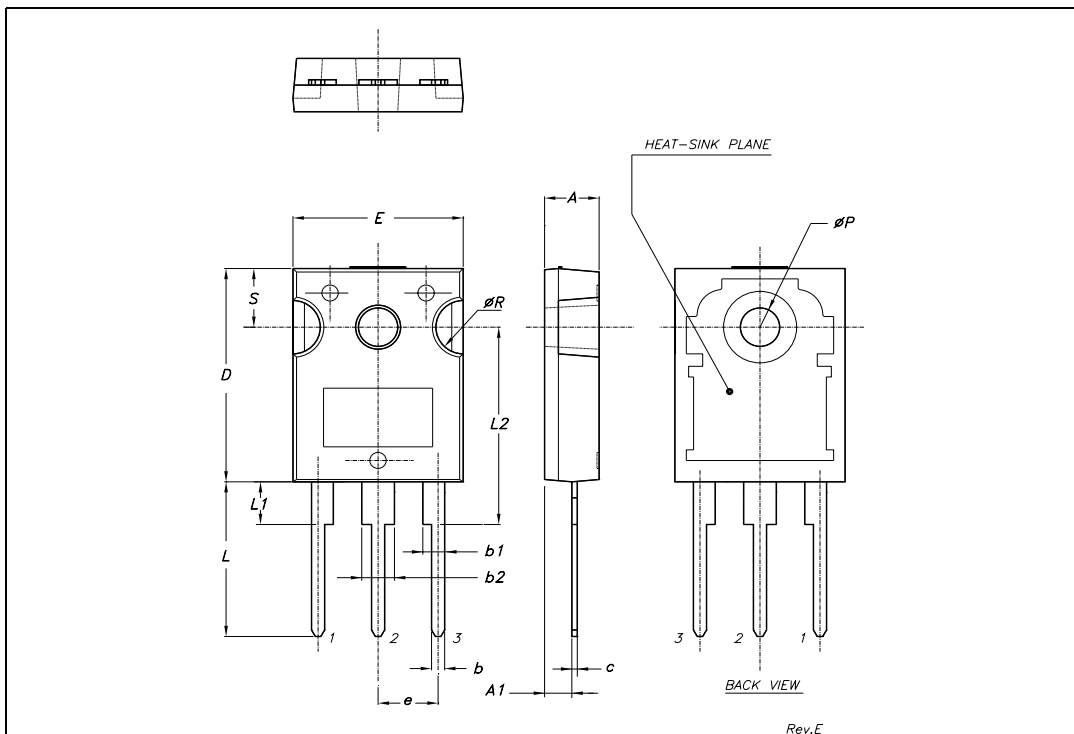

**D<sup>2</sup>PAK MECHANICAL DATA**

DIM.	mm.			inch		
	MIN.	TYP	MAX.	MIN.	TYP.	MAX.
A	4.4		4.6	0.173		0.181
A1	2.49		2.69	0.098		0.106
A2	0.03		0.23	0.001		0.009
B	0.7		0.93	0.027		0.036
B2	1.14		1.7	0.044		0.067
C	0.45		0.6	0.017		0.023
C2	1.23		1.36	0.048		0.053
D	8.95		9.35	0.352		0.368
D1		8			0.315	
E	10		10.4	0.393		
E1		8.5			0.334	
G	4.88		5.28	0.192		0.208
L	15		15.85	0.590		0.625
L2	1.27		1.4	0.050		0.055
L3	1.4		1.75	0.055		0.068
M	2.4		3.2	0.094		0.126
R		0.4			0.015	
V2	0°		4°			

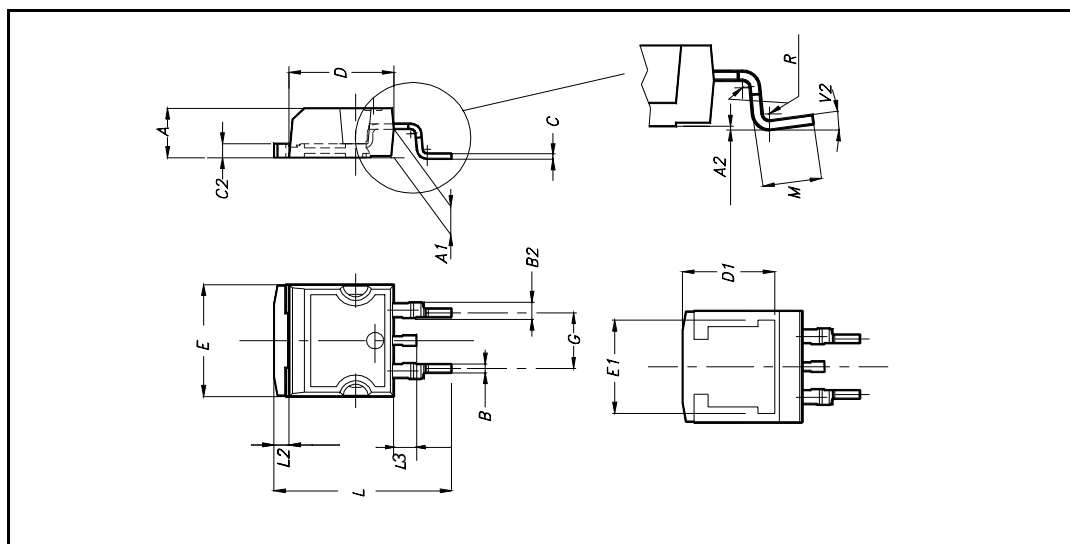

### D<sup>2</sup>PAK FOOTPRINT

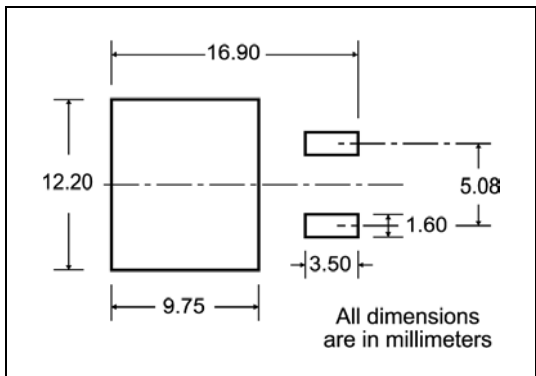

### TAPE AND REEL SHIPMENT

**TAPE MECHANICAL DATA**

DIM.	mm		inch	
	MIN.	MAX.	MIN.	MAX.
A0	10.5	10.7	0.413	0.421
B0	15.7	15.9	0.618	0.626
D	1.5	1.6	0.059	0.063
D1	1.59	1.61	0.062	0.063
E	1.65	1.85	0.065	0.073
F	11.4	11.6	0.449	0.456
K0	4.8	5.0	0.189	0.197
P0	3.9	4.1	0.153	0.161
P1	11.9	12.1	0.468	0.476
P2	1.9	2.1	0.075	0.082
R	50		1.574	
T	0.25	0.35	0.0098	0.0137
W	23.7	24.3	0.933	0.956

**REEL MECHANICAL DATA**

DIM.	mm		inch	
	MIN.	MAX.	MIN.	MAX.
A		330		12.992
B	1.5		0.059	
C	12.8	13.2	0.504	0.520
D	20.2		0.795	
G	24.4	26.4	0.960	1.039
N	100		3.937	
T		30.4		1.197

BASE QTY	BULK QTY
1000	1000

\* on sales type

## STB40N20 - STP40N20 - STW40N20

---

**Table 9: Revision History**

<b>Date</b>	<b>Revision</b>	<b>Description of Changes</b>
27-Sep-2004	1	First Release.
03-Feb-2005	2	Complete Version
03-Jun-2005	3	Update with D <sup>2</sup> PAK

Information furnished is believed to be accurate and reliable. However, STMicroelectronics assumes no responsibility for the consequences of use of such information nor for any infringement of patents or other rights of third parties which may result from its use. No license is granted by implication or otherwise under any patent or patent rights of STMicroelectronics. Specifications mentioned in this publication are subject to change without notice. This publication supersedes and replaces all information previously supplied. STMicroelectronics products are not authorized for use as critical components in life support devices or systems without express written approval of STMicroelectronics.

The ST logo is a registered trademark of STMicroelectronics

All other names are the property of their respective owners

© 2005 STMicroelectronics - All Rights Reserved

STMicroelectronics group of companies

Australia - Belgium - Brazil - Canada - China - Czech Republic - Finland - France - Germany - Hong Kong - India - Israel - Italy - Japan - Malaysia - Malta - Morocco - Singapore - Spain - Sweden - Switzerland - United Kingdom - United States of America