

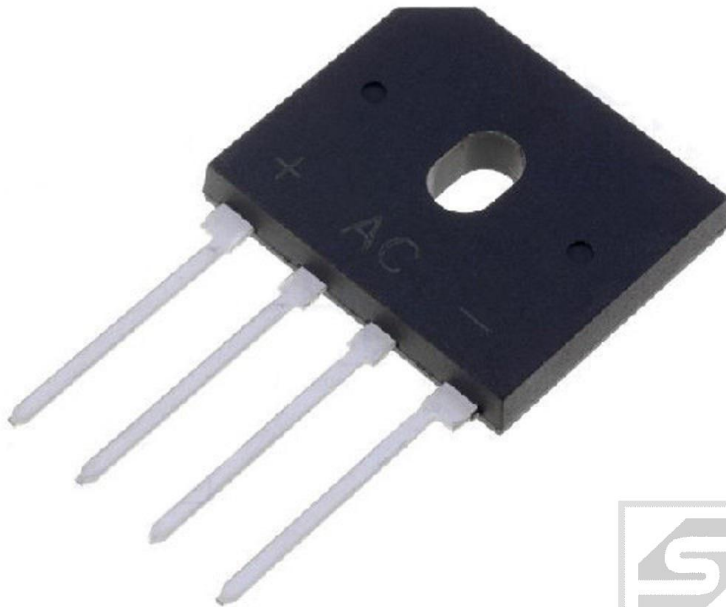

Mostek GBU10J (10A/600V) płaski LGE RoHS



Dane techniczne:

Nazwa: GBU10J

Typ elementu półprzewodnikowego: mostek prostowniczy

Napięcie wsteczne maksymalne: 600V

Prąd przewodzenia: 10A

Wersja: płaski

Montaż elektryczny: THT

GBU10A-GBU10M

Silicon Bridge Rectifiers

VOLTAGE RANGE: 50 --- 1000 V

CURRENT: 10.0 A



GBU

Features

- ◇ Ideal for printed circuit board
- ◇ Reliable low cost construction utilizing molded plastic technique
- ◇ Plastic material has U/L flammability classification 94V-0
- ◇ Mounting position: Any
- ◇ Glass passivated chip junctions

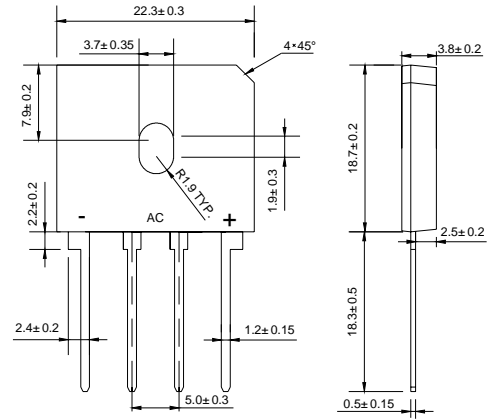

Dimensions in millimeters

MAXIMUM RATINGS AND ELECTRICAL CHARACTERISTICS

Ratings at 25°C ambient temperature unless otherwise specified.

Single phase, half wave, 60 Hz, resistive or inductive load. For capacitive load, derate by 20%.

		GBU 10A	GBU 10B	GBU 10D	GBU 10G	GBU 10J	GBU 10K	GBU 10M	UNITS
Maximum recurrent peak reverse voltage	V_{RRM}	50	100	200	400	600	800	1000	V
Maximum RMS voltage	V_{RMS}	35	70	140	280	420	560	700	V
Maximum DC blocking voltage	V_{DC}	50	100	200	400	600	800	1000	V
Maximum average forward output current @ $T_c=100^\circ\text{C}$	$I_{F(AV)}$	10							A
Peak forward surge current 8.3ms single half-sine-wave superimposed on rated load	I_{FSM}	200							A
Maximum instantaneous forward voltage at 5.0 A	V_F	1.1							V
Maximum reverse current @ $T_A=25^\circ\text{C}$ at rated DC blocking voltage @ $T_A=125^\circ\text{C}$	I_R	5.0 500							μA
Typical junction capacitance per leg (note 3)	C_J	211				94			pF
Typical thermal resistance per leg (note 2) (note 1)	$R_{\theta JA}$ $R_{\theta JC}$	21 2.2							$^\circ\text{C}/\text{W}$
Operating junction temperature range	T_J	- 55 ---- + 150							$^\circ\text{C}$
Storage temperature range	T_{STG}	- 55 ---- + 150							$^\circ\text{C}$

NOTE: 1. Unit case mounted on 3.2x3.2x0.12" thick (6.2x8.2x0.3cm) Al. Plate.

2. Units mounted in free air, no heat sink on P.C.B., 0.5x0.5"(12x12mm) copper pads, 0.375"(9.5mm) lead length.

3. Measured at 1.0 MHz and applied reverse voltage of 4.0 volts.

GBU10A-GBU10M

Silicon Bridge Rectifiers

Ratings AND Characteristic Curves

FIG.1 – DERATING CURVE FOR OUTPUT RECTIFIED CURRENT

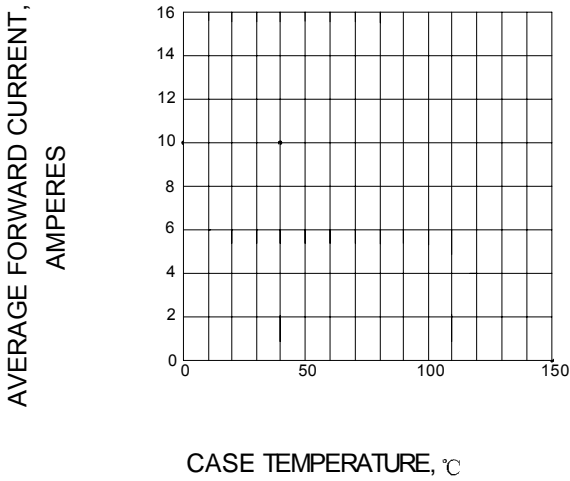

FIG.2 – TYPICAL FORWARD CHARACTERISTIC

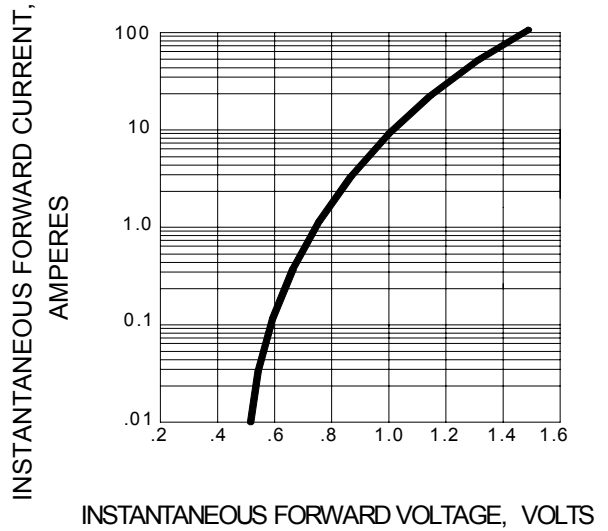

FIG.3 – MAXIMUM NON-REPETITIVE PEAK FORWARD SURGE CURRENT

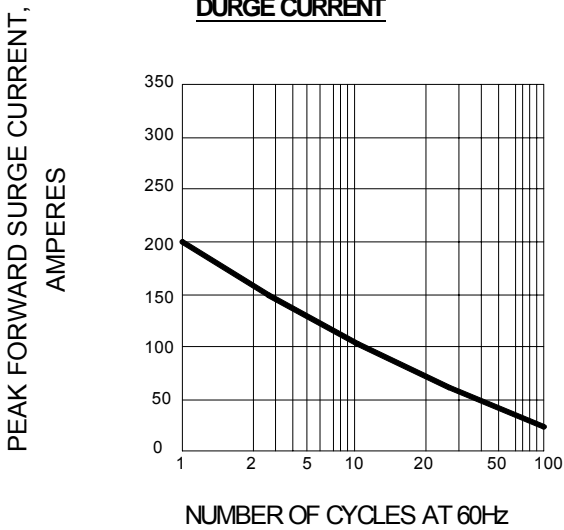

FIG.4 – TYPICAL REVERSE CHARACTERISTIC

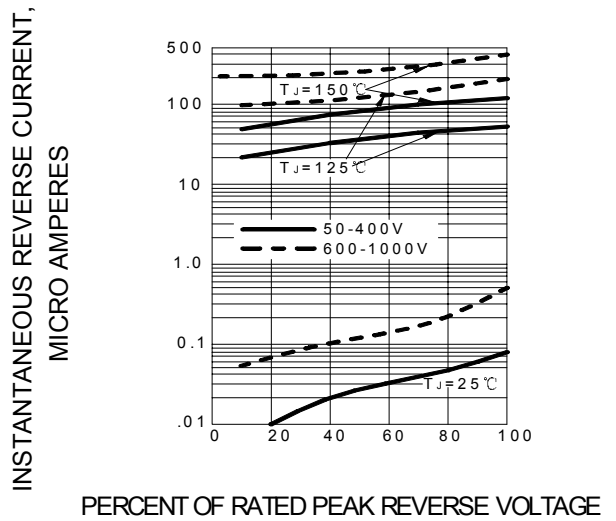

FIG.5 – TYPICAL JUNCTION CAPACITANCE PER LEG

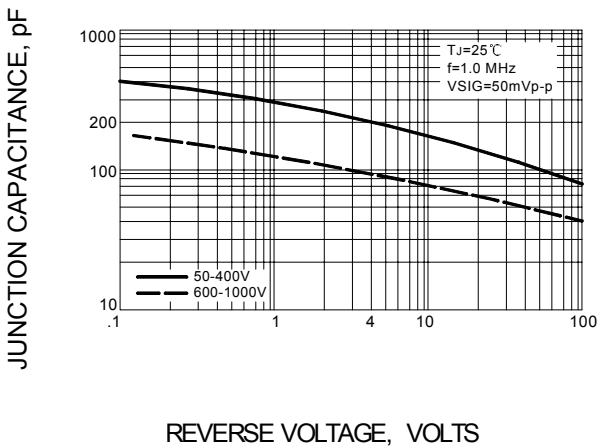

FIG.6 – TYPICAL TRANSIENT THERMAL IMPEDANCE

