



Typical Applications

Central door lock, Power doors & windows, Turning lamp control, Mirror adjustment, Seat adjustment, Speed-limit indicator control, Warm-up control, Wiper control

Features

- High current contact capacity
(Carrying current: 35A/10min 25A/1h)
- Improved heat resistance
- High resistance to vibration and shock
- Reflow soldering version available
- RoHS & ELV compliant

CHARACTERISTICS

Contact arrangement	1A, 1C
Voltage drop (initial) ¹⁾	Typ.: 50mV (at 10A)
	Max. : 250mV (at 10A)
Max. continuous current ²⁾	35A (at 23°C, 10min)
	25A (at 23°C, 1h)
Max. switching current ³⁾	NO: 40A
	NC: 20A
Max. switching voltage ⁴⁾	30VDC
Min. contact load	1A 6VDC
Electrical endurance	See "CONTACT DATA"
Mechanical endurance	1 x 10 ⁷ OPS (300OPS/min)
Initial insulation resistance	100MΩ (at 500VDC)
Dielectric strength	500VAC (1min, leakage current less than 1mA)

Operate time	Max.: 10ms (at nomi. vol.)
Release time	Max.: 5ms ⁵⁾
Ambient temperature	-40°C to 85°C
Vibration resistance ⁶⁾	10Hz to 55Hz 1.5mm DA
Shock resistance ⁶⁾	98m/s ²
Termination	PCB ⁷⁾
Construction	Wash tight, Flux proofed
Unit weight	Approx. 6g

- 1) Equivalent to the max. initial contact resistance is 100mΩ (1A 6VDC).
 2) For NO contacts, measured when applying 100% rated voltage on coil.
 3) At 23°C, 13.5VDC (100 cycles).
 4) See "Max. switching power" curve for details.
 5) The value is measured when voltage drops suddenly from nominal voltage to 0 VDC and coil is not paralleled with suppression circuit.
 6) When energized, release time of NO contacts shall not exceed 100μs, when non-energized, release time of NC contacts shall not exceed 100μs, meantime, NO contacts shall not be closed.
 7) Since it is an environmental friendly product, please select lead-free solder when welding. The recommended soldering temperature and time is 240°C to 260°C, 2s to 5s.

CONTACT DATA ⁵⁾

at 23°C

Load voltage	Load type		Load current A			On/Off ratio		Electrical endurance OPS	Contact material	Load wiring diagram ⁴⁾
			1C		1A	On s	Off s			
			NO	NC	NO					
13.5VDC	Resistive	Make	15	15	15	2	2	2×10 ⁵	AgSnO ₂	See diagram 1
		Break	15	15	15	2	2			See diagram 2
	Resistive	Make	30	---	30	5	5	1×10 ⁵	AgSnO ₂	See diagram 2
		Break	30	---	30					
	Motor Locked	Make	25 ³⁾	---	25 ³⁾	1	9	1×10 ⁵	AgSnO ₂	See diagram 3
		Break	25 ³⁾	---	25 ³⁾					

Load voltage	Load type		Load current A			On/Off ratio		Electrical endurance OPS	Contact material	Load wiring diagram ⁴⁾
			1C		1A	On s	Off s			
			NO	NC	NO					
13.5VDC	Lamp ¹⁾	Make	90 ²⁾	---	90 ²⁾	1	9	1×10 ⁵ (at 85°C)	AgSnO ₂	See diagram 4
		Break	8.8	---	8.8					
	Lamp ¹⁾	Make	6×21W	---	6×21W	1	6	1×10 ⁵	AgSnO ₂	See diagram 4
		Break								
	Flasher	Make	3×21W	---	3×21W	0.365	0.365	2×10 ⁶	Special AgSnO ₂	See diagram 5
		Break								

1) When it is utilized in flasher, a special AgSnO₂ contact material should be used and the customer special code should be (170) as a suffix. Please connect by the polarity according to the diagram below.

2) Corresponds to the peak inrush current on initial actuation (cold filament).

3) Corresponds to the peak inrush current on initial actuation (motor).

4) The load wiring diagrams are listed below (Ratings of NO, NC are tested based on different samples separately) :

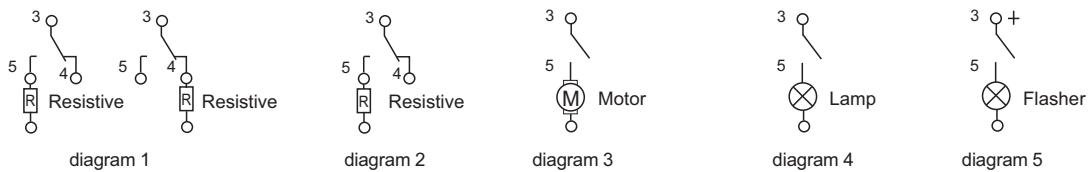

5) When the load voltage is at 24VDC or higher, or the applications conditions are different from the table above, please submit the detailed application conditions to Hongfa to get more support.

COIL DATA

at 23°C

Nominal voltage VDC	Pick-up voltage VDC		Drop-out voltage VDC	Coil resistance x(±10%)Ω	Power consumption W	Max. allowable overdrive voltage ¹⁾ VDC	
	at 23°C	at 85°C				at 23°C	at 85°C
6	3.6	4.5	0.5	60	0.6	10	8
9	5.4	6.8	0.7	135	0.6	15	12
10	6.3	7.9	0.8	180	0.6	16.7	13.3
12	7.3	9.0	1.0	240	0.6	20	16
18	10.8	13.5	1.5	540	0.6	30	24
24	14.4	18.0	2.2	960	0.6	40	32

1) Max. allowable overdrive voltage is stated with no load applied.

ORDERING INFORMATION

Type	HFKW /	012	-1Z	W	-L	C	(XXX)
Coil voltage	006: 6VDC	009: 9VDC	010: 10VDC	012: 12VDC	018: 18VDC	024: 24VDC	
Contact arrangement	1H: 1 Form A	1Z: 1 Form C					
Contact material	W: AgSnO ₂						
Construction	L: Flux proofed	Nil: Wash tight					
Packing style	C: Tape and reel packing	Nil: Tube packing					
Customer special code	e.g. (170) stands for flasher load						

OUTLINE DIMENSIONS, WIRING DIAGRAM AND PC BOARD LAYOUT

Unit: mm

Outline Dimensions

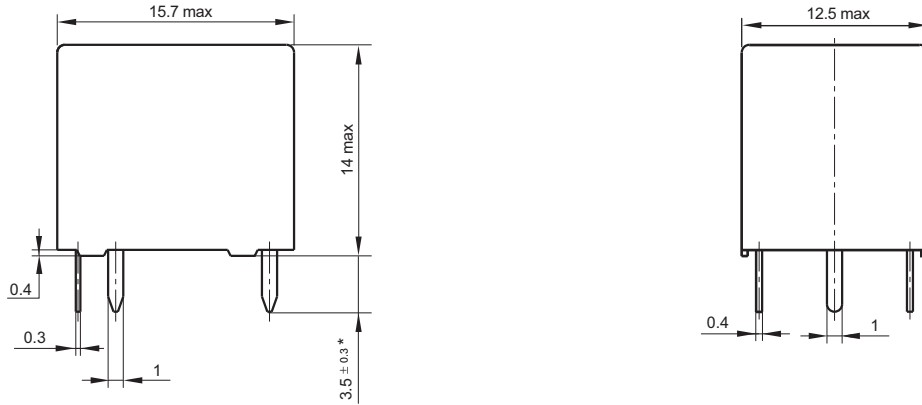

PCB Layout (Bottom view)

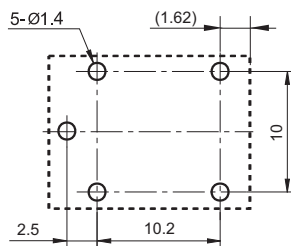

Wiring Diagram (Bottom view)

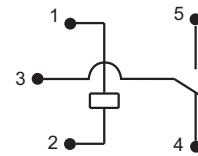

- Notes:** 1) * The additional tin top is max. 1mm.
 2) The tolerance without indicating is always ± 0.1 mm.

TAPE AND REEL PACKING

Unit: mm

Direction of Relay Insertion

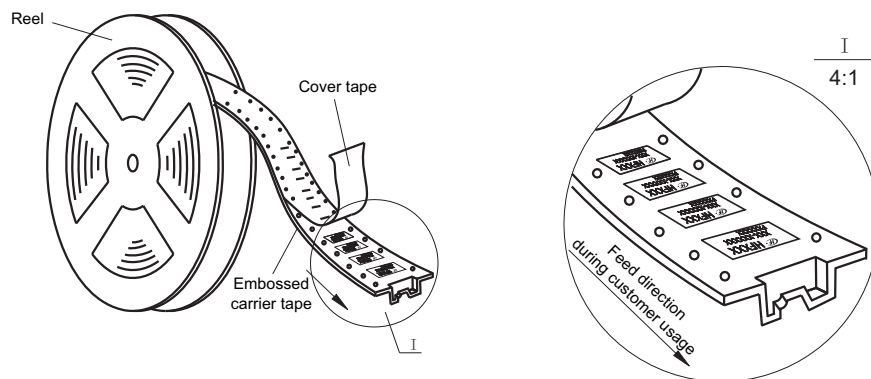

Direction of Relay Insertion

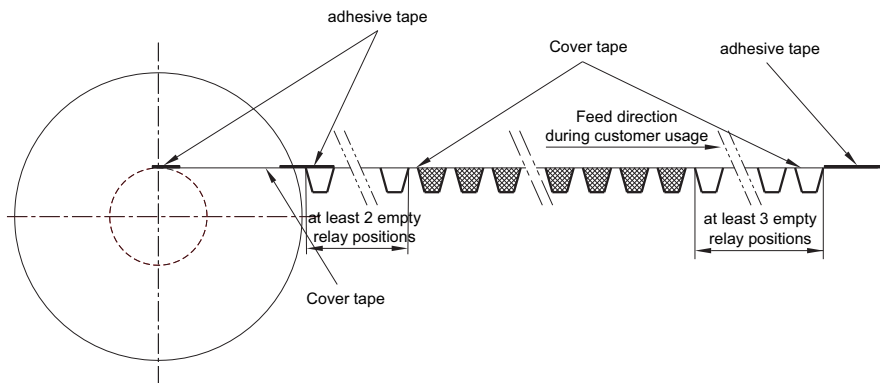

Reel Dimensions

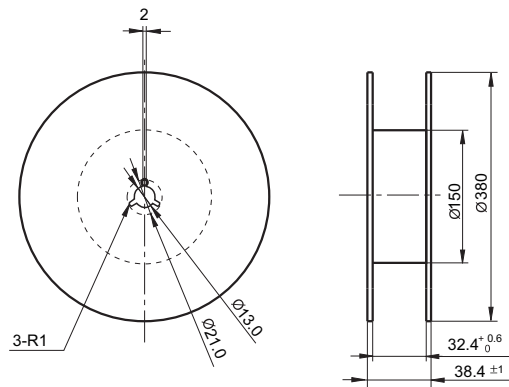

Tape Dimensions

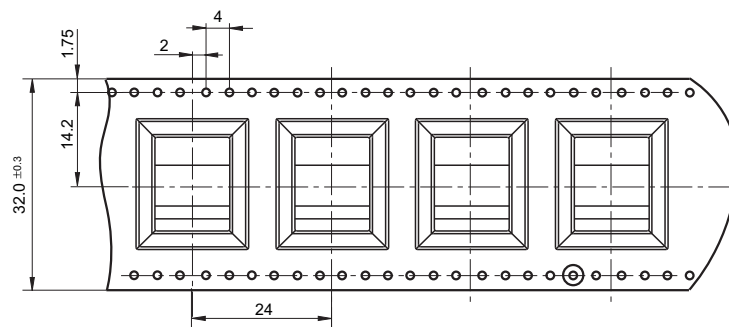

CHARACTERISTIC CURVES

1. Coil operating voltage range (NO contacts, at 13.5VDC)

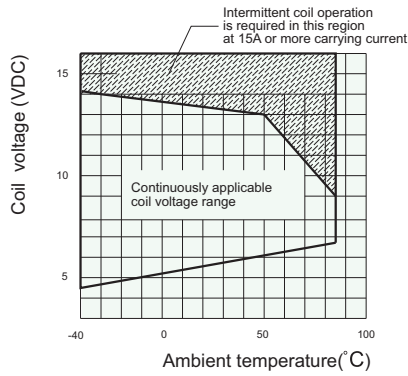

HFKW/009-1ZW

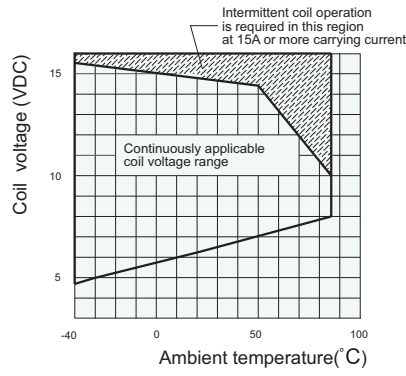

HFKW/010-1ZW

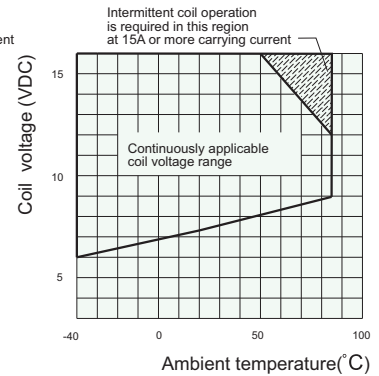

HFKW/012-1ZW

2. Load curve (NO contacts, at 23°C)

Electrical endurance curve (Motor locked)

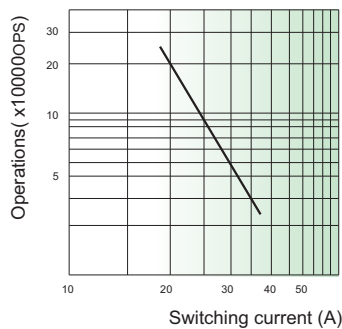

HFKW/012-1ZW

Max. switching power

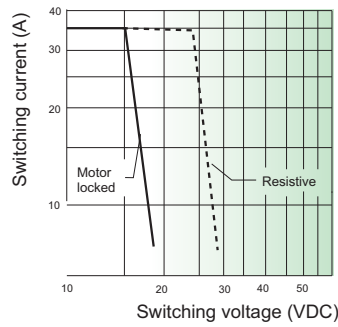

HFKW/012-1ZW

Coil temperature rise

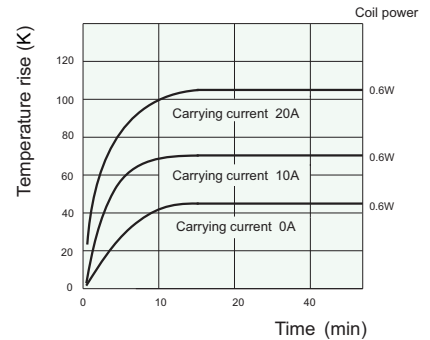

HFKW/012-1ZW

Disclaimer

This datasheet is for the customers' reference. All the specifications are subject to change without notice.

We could not evaluate all the performance and all the parameters for every possible application. Thus the user should be in a right position to choose the suitable product for their own application. If there is any query, please contact Hongfa for the technical service. However, it is the user's responsibility to determine which product should be used only.