

VOLTAGE COMPARATORS

- MAXIMUM INPUT CURRENT : 150nA
- MAXIMUM OFFSET CURRENT : 20nA
- DIFFERENTIAL INPUT VOLTAGE RANGE : $\pm 30V$
- POWER CONSUMPTION : 135mW AT $\pm 15V$
- SUPPLY VOLTAGE : +5V TO $\pm 15V$
- OUTPUT CURRENT : 50mA

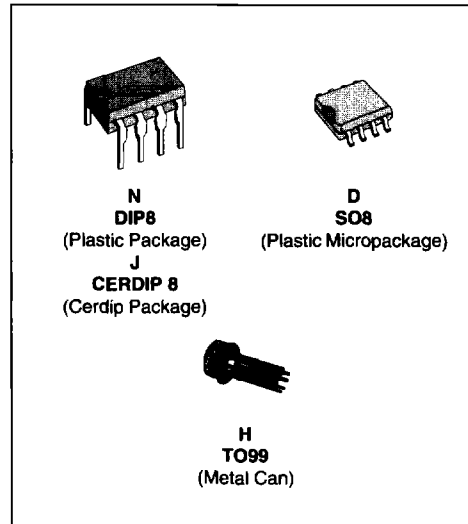

DESCRIPTION

The LM111, LM211 and LM311 are voltage comparators that have low input currents.

They are also designed to operate over a wide range of supply voltages : from standard $\pm 15V$ operational amplifier supplies down to the single +5V supply used for IC logic.

Their output is compatible with RTL-DTL and TTL as well as MOS circuits and can switch voltages up to +50V at output currents as high as 50mA.

ORDER CODES

Part Number	Temperature Range	Package			
		H	N	J	D
LM111	-55, 125°C	•	•	•	•
LM211	-40, 105°C	•	•	•	•
LM311	0, 70°C	•	•	•	•

Examples : LM111H, LM111J

111-01.TBL

PIN CONNECTIONS (top views)

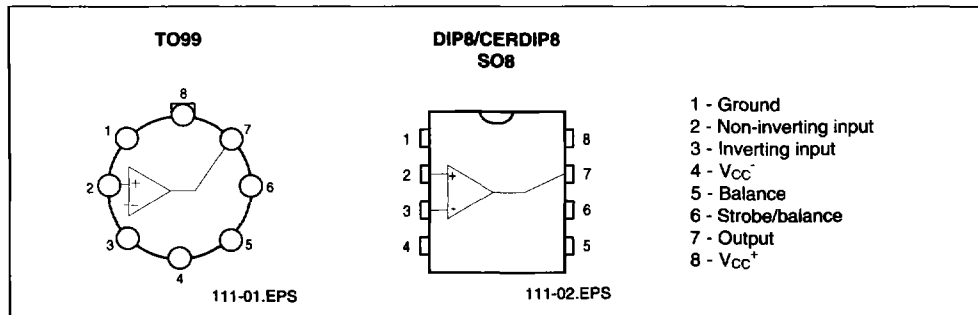

SCHEMATIC DIAGRAM

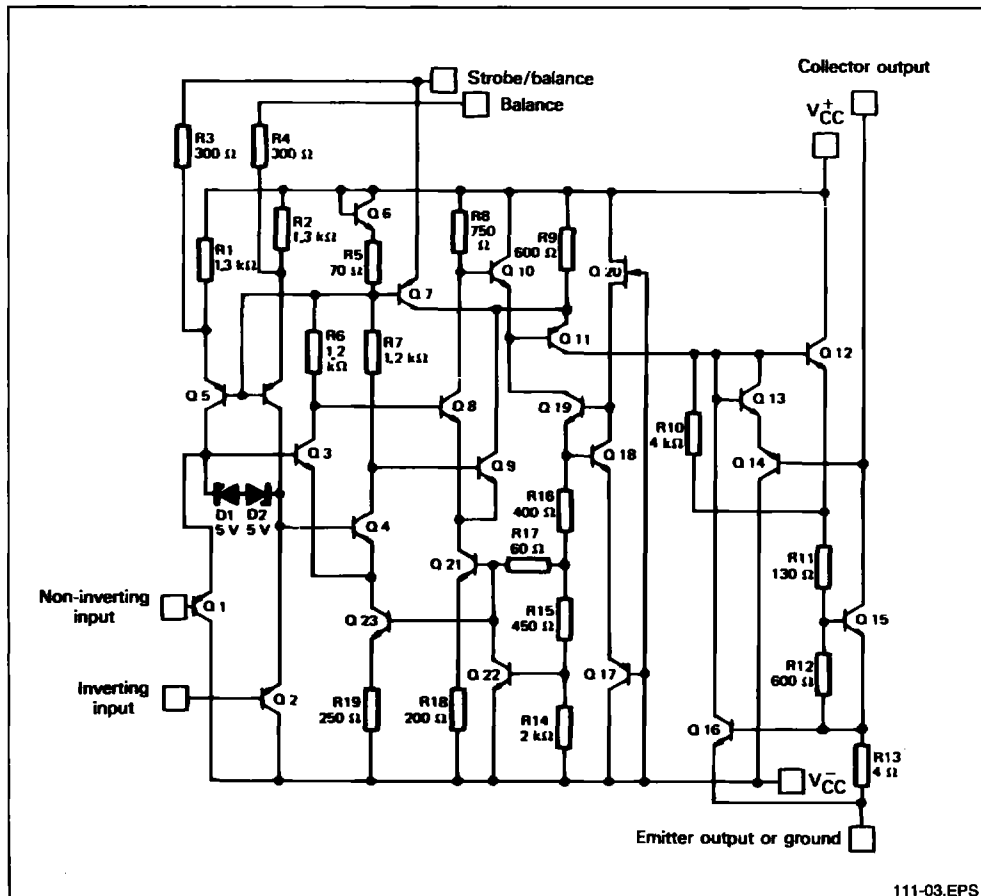

111-03.EPS

ABSOLUTE MAXIMUM RATINGS

Symbol	Parameter	LM111	LM211	LM311	Unit
V _{CC}	Supply Voltage	36	36	36	V
V _{id}	Differential Input Voltage	±30	±30	±30	V
V _i	Input Voltage - (note 1)	±15	±15	±15	V
P _{tot}	Power Dissipation	500			mW
T _{oper}	Operating Free-air Temperature Range	-55 to +125	-40 to +105	0 to +70	°C
T _{stg}	Storage Temperature Range	-65 to +150	-65 to +150	-65 to +150	°C
V ₍₁₋₄₎	Ground to Negative Supply Voltage	30	30	30	V
V ₍₇₋₄₎	Output to Negative Supply Voltage	50	50	40	V

Output short-circuit duration : 10s
Voltage at strobe pin : V_{CC} - 5V

Maximum junction temperature

LM111 : +150°C
LM211 : +150°C
LM311 : +150°C

Note : 1. This rating applies for ±15V supplies. The positive input voltage limit is 30V above the negative. The negative input voltage limit is equal to the negative supply voltage or 30V below the positive supply, whichever is less.

ELECTRICAL CHARACTERISTICS

 $V_{CC} = \pm 15V$, $T_{amb} = 25^{\circ}C$ (unless otherwise specified)

Symbol	Parameter	LM111 - LM211			LM311			Unit
		Min.	Typ.	Max.	Min.	Typ.	Max.	
V_{io}	Input Offset Voltage ($R_S \leq 50k\Omega$) – (note 1) $T_{amb} = +25^{\circ}C$ $T_{min.} \leq T_{amb} \leq T_{max.}$		0.7	3 4		2	7.5 10	mV
I_{io}	Input Offset Current – (note 1) $T_{amb} = +25^{\circ}C$ $T_{min.} \leq T_{amb} \leq T_{max.}$		4	10 20		6	50 70	nA
I_{ib}	Input Bias Current – (note 1) $T_{amb} = +25^{\circ}C$ $T_{min.} \leq T_{amb} \leq T_{max.}$		60	100 150		100	250 300	nA
A_{vd}	Large Signal Voltage Gain	40	200		40	200		V/mV
I_{CC}^{+} I_{CC}^{-}	Supply Currents Positive Negative		5.1 4.1	6 5		5.1 4.1	7.5 5	mA
V_{icm}	Input Common Mode Voltage Range $T_{min.} \leq T_{amb} \leq T_{max.}$	-14.5	+13.8 -14.7	+13	-14.5	+13.8 -14.7	+13	V
V_{OL}	Low Level Output Voltage $T_{amb} = +25^{\circ}C$, $I_O = 50mA$ $V_{i1} \leq -5mV$ $V_{i1} \leq -10mV$ $T_{min.} \leq T_{amb} \leq T_{max.}$ $V_{CC}^{+} \geq +4.5V$, $V_{CC}^{-} = 0$ $I_{sink} = 8mA$ $V_{i1} \leq -6mV$ $V_{i1} \leq -10mV$		0.75 0.23	1.5 0.4		0.75 0.23	1.5 0.4	V
I_{OH}	High Level Output Current $T_{amb} = +25^{\circ}C$ $T_{min.} \leq T_{amb} \leq T_{max.}$ $V_{i1} \geq +5mV$, $V_O = +35V$ $V_{i1} \geq +10mV$, $V_O = +5V$ $V_{i1} \geq +5mV$, $V_O = +35V$		0.2 0.1	10 0.5		0.2	50	nA nA μA
I_{strobe}	Strobe Current		3			3		mA
t_{re}	Response Time – (note 2)		200			200		ns

Notes : 1. The offset voltage, offset current and bias current specifications apply for any supply voltage from a single +5V supply up to $\pm 15V$ supplies.

The offset voltages and offset currents given are the maximum values required to drive the output down to +1V or up to +14V with a 1mA load current. Thus, these parameters define an error band and take into account the worst-case of voltage gain and input impedance.

2. The response time specified (see definitions) is for a 100mV input step with 5mV overdrive.

111-03.TBL

TRANSFER CHARACTERISTICS

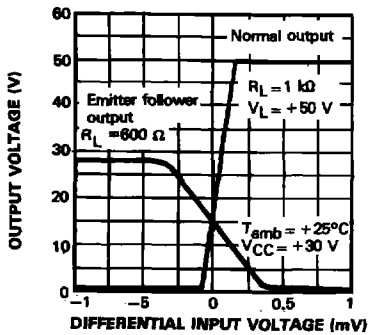

OUTPUT LIMITING CHARACTERISTICS

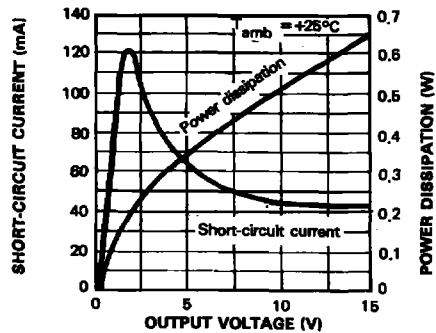

COMMON MODE LIMITS

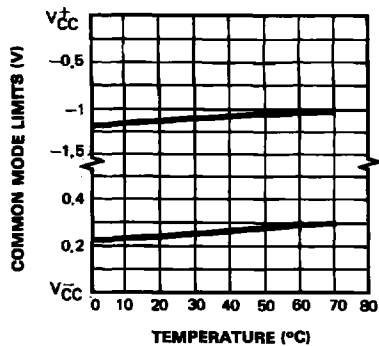

INPUT OFFSET CURRENT

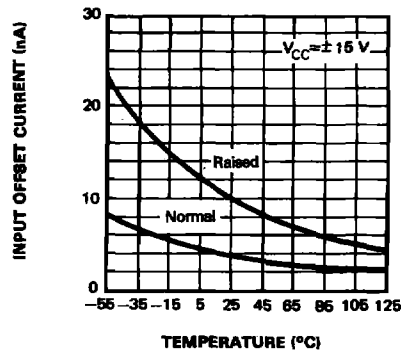

INPUT BIAS CURRENT

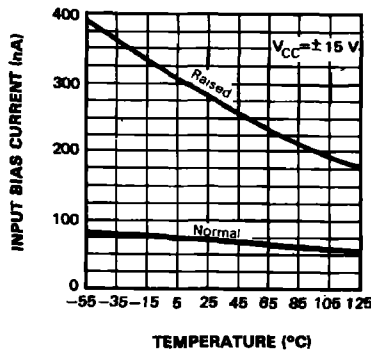

111-04.EPS

EQUIVALENT INPUT OFFSET ERROR

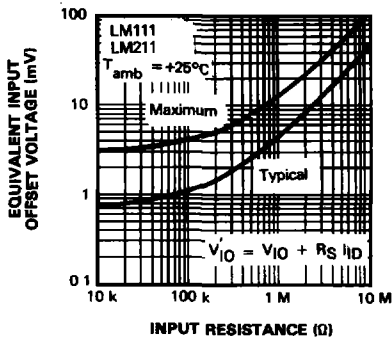

EQUIVALENT INPUT OFFSET ERROR

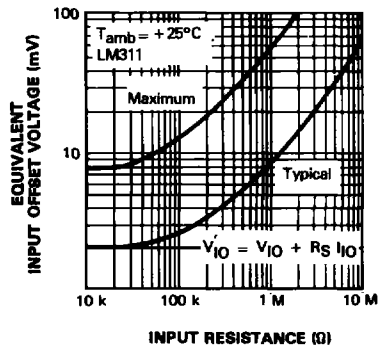

LOW LEVEL OUTPUT SATURATION VOLTAGE

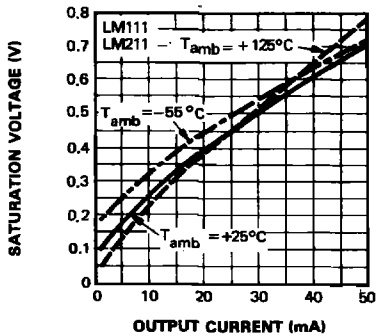

LOW LEVEL OUTPUT SATURATION VOLTAGE

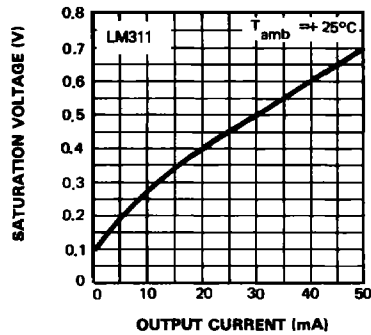

INPUT CHARACTERISTICS

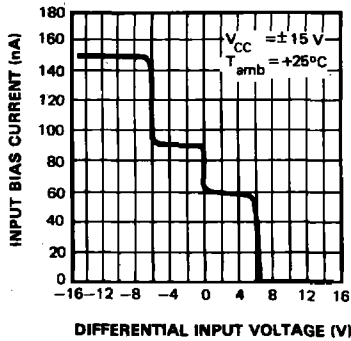

RESPONSE TIME FOR VARIOUS
INPUT OVERDRIVES

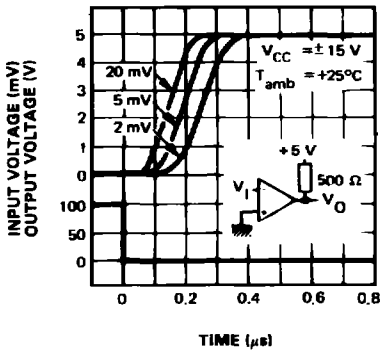

RESPONSE TIME FOR VARIOUS
INPUT OVERDRIVES

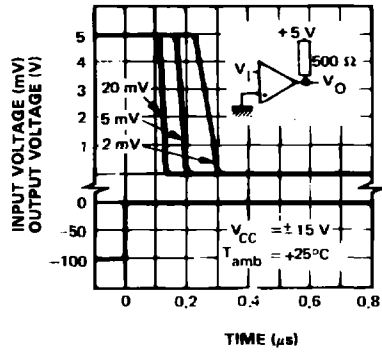

RESPONSE TIME FOR VARIOUS
INPUT OVERDRIVES

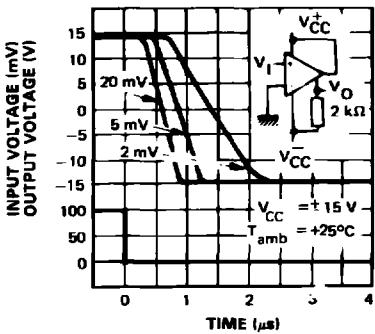

RESPONSE TIME FOR VARIOUS
INPUT OVERDRIVES

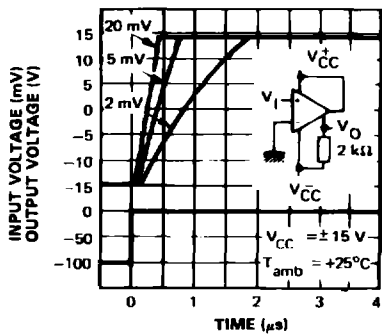

111-06.EPS

TYPICAL APPLICATIONS

CRYSTAL OSCILLATOR

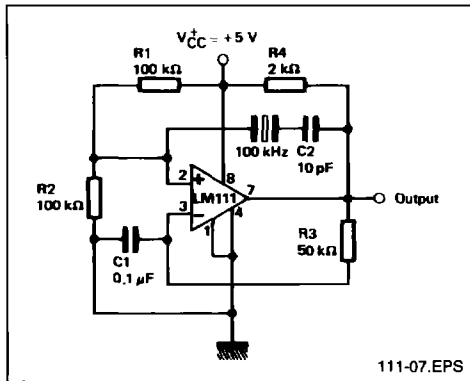

100kHz FREE RUNNING MULTIVIBRATOR

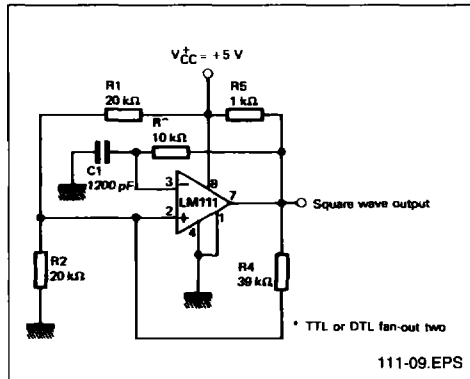

AUXILIARY CIRCUITS

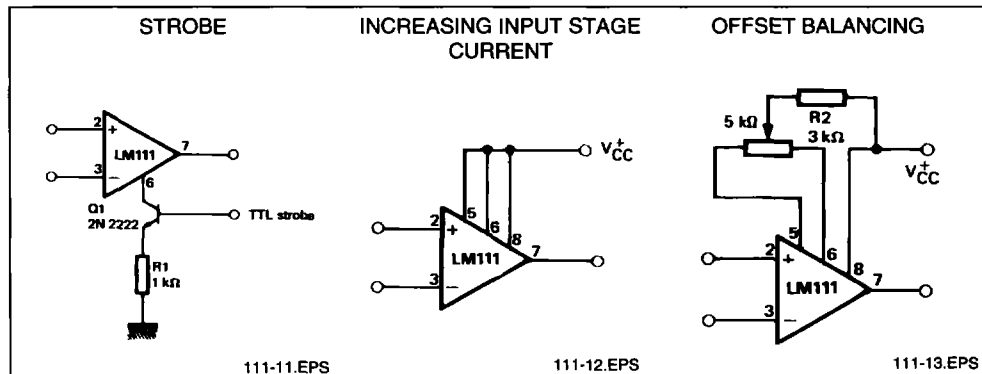

LOW VOLTAGE ADJUSTABLE REFERENCE SUPPLY

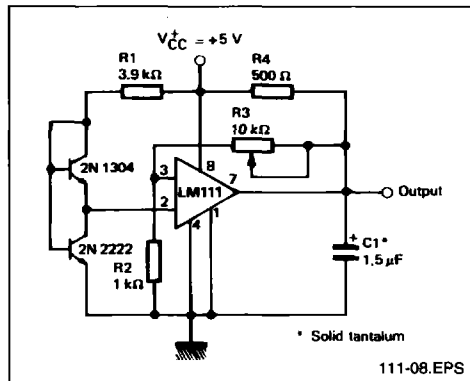

TTL INTERFACE WITH HIGH LEVEL LOGIC

